

# **Santa Monica Bay Jurisdictional Group 2 and 3 Enhanced Watershed Management Program - DRAFT**

Prepared by:  
**City of Los Angeles  
Los Angeles County Flood Control District  
County of Los Angeles  
City of Santa Monica  
City of El Segundo  
June 29, 2015**



The MWH Team



Geosyntec  
consultants



M2 Resource Consulting, Inc.





# Table of Contents

Section Name	Page Number
Executive Summary .....	x
<b>Section 1 Introduction .....</b>	<b>1</b>
1.1. APPLICABILITY OF EWMP .....	2
1.2. GEOGRAPHICAL SCOPE AND CHARACTERISTICS .....	2
1.3. REGULATORY FRAMEWORK .....	5
1.3.1. MS4 Permit Requirements .....	5
1.3.2. Relevant Total Maximum Daily Loads .....	5
1.4. ENHANCED WATERSHED MANAGEMENT PROGRAM DEVELOPMENT PROCESS ..	8
<b>Section 2 Identification of Water Quality Priorities.....</b>	<b>10</b>
2.1. WATER QUALITY CHARACTERIZATION .....	10
2.2. WATER BODY-POLLUTANT PRIORITIZATION .....	13
2.3. SOURCE ASSESSMENT .....	14
2.3.1. Indicator Bacteria .....	14
2.3.2. DDT and PCBs.....	16
2.3.3. Lead.....	16
<b>Section 3 Reasonable Assurance Analysis .....</b>	<b>17</b>
3.1. MODELING SYSTEM .....	17
3.2. RAA PROCESS OVERVIEW .....	19
3.2.1. Reasonable Assurance Analysis Approach - Dry Weather .....	19
3.2.2. RAA Approach – Wet Weather .....	20
3.2.3. Methods to Identify and Prioritize BMP Opportunities .....	22
3.3. MODELING APPROACH.....	22
3.3.1. BMP Objectives .....	22
3.3.2. Non-Structural BMPs.....	22
3.3.3. Non-Modeled Non-Structural BMPs .....	22
3.3.4. Modeling Redevelopment Projects .....	23
3.3.5. Modeling Public Retrofit Incentives .....	24
3.3.6. Modeling Inspection of Non-MS4 Permitted Parcels or Areas.....	24
3.3.7. Modeling Distributed Green Street BMPs .....	24
3.3.8. Regional/Centralized Design Parameters and Criteria.....	27
<b>Section 4 Watershed Control Measures .....</b>	<b>28</b>
4.1. INSTITUTIONAL BMPS .....	28

# Table of Contents

---

4.2.	STRUCTURAL BMPS .....	32
4.2.1.	Existing Regional BMPs .....	33
4.2.2.	Existing Distributed BMPs.....	33
4.2.3.	Planned Structural BMPs for Compliance .....	35
4.2.4.	Regional Projects .....	40
4.2.5.	Green Streets .....	61
4.2.6.	Additional Structural BMPs.....	66
4.3.	NON-STORM WATER DISCHARGE CONTROL MEASURES .....	67
<b>Section 5</b>	<b>EWMP Implementation Schedule .....</b>	<b>68</b>
5.1.	COMPLIANCE SCHEDULE OF STORMWATER CONTROL MEASURES .....	68
5.2.	STORMWATER CONTROL MEASURES TO BE IMPLEMENTED BY 2018 FOR BACTERIAL MILESTONE COMPLIANCE.....	69
5.3.	STORMWATER CONTROL MEASURES TO BE IMPLEMENTED BY 2021 FOR BACTERIAL MILESTONE COMPLIANCE.....	71
5.4.	OTHER IMPLEMENTATION ACTIVITIES FOR TMDL COMPLIANCE .....	73
5.4.1.	Non-Structural BMPs.....	73
5.4.2.	Public Retrofit Incentives for BMPs .....	73
5.4.3.	Non-stormwater Control Measures .....	73
5.5.	OTHER CONSTITUENTS AND TMDL COMPLIANCE .....	73
5.6.	SUMMARY OF PERMITTEE ACTIONS .....	74
<b>Section 6</b>	<b>Assessment and Adaptive Management Framework.....</b>	<b>75</b>
6.1	ADAPTIVE MANAGEMENT PROCESS .....	75
6.1.1.	Re-Characterization of Water Quality Priorities .....	75
6.1.2.	Source Assessment Re-Evaluation.....	76
6.1.3.	Effectiveness Assessment of Watershed Control Measures.....	76
6.1.4.	Update of Reasonable Assurance Analysis .....	76
6.2	REPORTING.....	76
<b>Section 7</b>	<b>EWMP Implementation Costs and Financial Strategy.....</b>	<b>77</b>
7.1.	EWMP COSTS.....	77
7.1.1.	EWMP Costs by BMP and TMDL Milestones.....	78
7.1.2.	EWMP Costs by Watershed.....	79
7.2.	IMPACT OF EWMP COSTS.....	79
7.3.	EXISTING STORMWATER PROGRAMS .....	79
7.4.	FINANCIAL STRATEGIES.....	80
7.4.1.	Grants .....	81

## Table of Contents

---

7.4.2.	Fees and Charges.....	81
7.4.3.	Legislative and Policy.....	81
7.4.4.	Future Steps.....	82
<b>Section 8</b>	<b>Legal Authority .....</b>	<b>83</b>
<b>Section 9</b>	<b>References .....</b>	<b>84</b>

# List of Appendices

---

## **Appendix Name**

Appendix A: Reasonable Assurance Analysis

Appendix B: Concept Report

Appendix C: Field Investigation/Environmental Checklist

Appendix D: Geotechnical Evaluation

Appendix E: Legal Authority Certification

Appendix F: Existing and Potential Control Measures

Appendix G: El Segundo Plastic Pellets Memo

# List of Tables

<b>Table Name</b>	<b>Page Number</b>
Table 1-1 Santa Monica Bay EWMP Area Subwatersheds and Associated Water Bodies/Tributaries .....	5
Table 1-2 303(d) – Listed Water Bodies in the SMB Watershed .....	6
Table 1-3 North Santa Monica Bay Coastal Watersheds (NSMBCW) TMDLs.....	7
Table 1-4 Final Permit RWLs and WQBELs for SMB TMDLs .....	8
Table 2-1 Beneficial Uses of Water Bodies and Coastal Features Designed in the Basin Plan .....	12
Table 2-2 Description of Water Body-Pollutant Prioritization Categories .....	13
Table 2-3 Water Body Pollutant Prioritization <sup>1</sup> .....	13
Table 3-1 Assumed Annual Redevelopment Rates.....	23
Table 3-2 Redevelopment, Public Retrofit Incentives, and Distributed Green Street BMP Model Assumptions.....	25
Table 3-3 CML Analysis Region-Specific 85 <sup>th</sup> Percentile, 24-Hour Design Storm Depths.....	26
Table 3-4 Non-MS4 Parcels – Modeled as Treated by Treatment Plants.....	26
Table 4-1 Comparison of Stormwater Management Program MCMs.....	30
Table 4-2 Summary of Existing Regional Best Management Practices <sup>1</sup> by Permittee and Type.....	33
Table 4-3 Existing Distributed Best Management Practices by Permittee and Type .....	35
Table 4-4 Summary of Regional Structural Capacity Required by Permittee for Compliance .....	38
Table 4-5 Summary of Distributed BMP Capacity Required by Permittee for Compliance.....	38
Table 4-6 Summary of Regional and Centralized BMPs Required for Compliance .....	39
Table 4-7 Summary of Planned/Proposed Regional Projects and Green Street Area by Agency .....	40
Table 4-8 Summary Proposed of Regional EWMP Projects .....	42
Table 4-9 Rational Method Inputs .....	50
Table 4-10 Conceptual Design Inputs.....	51
Table 4-11 CMP Infiltration/Storage Sizing <sup>1</sup> .....	52
Table 4-12 Estimated Excavation and Backfill Volumes of BMP .....	52
Table 5-1 Summary of Regional and Centralized BMPs Required Compliance in 2018.....	70
Table 5-2 Summary of Regional and Centralized BMPs Required Compliance in 2021.....	72
Table 5-3 Regional BMP Capacity Required for Compliance (Acre-feet).....	72
Table 5-4 Green Street BMP Capacity Required for Compliance (Acre-feet) .....	72
Table 7-1 Conceptual Design Major Components Unit Cost .....	78
Table 7-2 Total Costs by Milestone (\$ Millions) <sup>1</sup> .....	79
Table 7-3 Total Costs by Agency (\$ Millions) .....	79
Table 7-4 Existing Stormwater Costs .....	80

# List of Figures

---

<b>Figure Name</b>	<b>Page Number</b>
Figure 1-1 Santa Monica Bay EWMP Group Area .....	3
Figure 1-2 Santa Monica Bay Subwatersheds .....	4
Figure 2-1 Receiving Waters in the SMB EWMP Group Area .....	11
Figure 3-1 Structural BMP Prioritization and Analysis Tool (SBPAT) .....	18
Figure 3-2 Structural BMP Prioritization and Analysis Tool Monte Carlo Methodology .....	19
Figure 3-3 Modeled Analysis Regions within the SMB EWMP Group Area .....	21
Figure 4-1 Process for Minimum Control Measure Customization .....	29
Figure 4-2 General Classification of Outcome types (adapted from CASQA) .....	32
Figure 4-3 Location of Existing Regional BMPs .....	34
Figure 4-4 Process for Evaluating Regional EWMP Projects .....	36
Figure 4-5 High Potential Regional Sites .....	37
Figure 4-6 Eight Proposed Regional EWMP Projects .....	43
Figure 4-7 Conceptual Infiltration Basin Schematic .....	45
Figure 4-8 Conceptual Subsurface Infiltration System Using CMP .....	46
Figure 4-9 Photograph Storage/Detention System Using CMP .....	47
Figure 4-10 Conceptual Diversion Structure Drawing .....	48
Figure 4-11 Example CDS Pretreatment Unit .....	49
Figure 4-12 Brentwood Country Club Project Concept .....	54
Figure 4-13 Oakwood Recreation Center Project Concept .....	55
Figure 4-14 Riviera Country Club Project Concept .....	56
Figure 4-15 Rustic Canyon Recreation Center Project Concept .....	57
Figure 4-16 Line B Pump Station Project Concept .....	58
Figure 4-17 Recreation Park Project Concept .....	59
Figure 4-18 Memorial Park Project Concept .....	60
Figure 4-19 Santa Monica Civic Auditorium and Courthouse Project Concept .....	61
Figure 4-20 Example Green Streets Project in Pacific Palisades – View 1 .....	62
Figure 4-21 Example Green Streets Project in Pacific Palisades – View 2 .....	63
Figure 4-22 Section View of Bioretention with Underdrain .....	64
Figure 4-23 Typical Distributed Green Street Schematic .....	65
Figure 4-24 Typical Distributed Permeable Pavement Schematic with Underdrain .....	65
Figure 4-25 Typical Bioswale Schematic .....	66

## List of Figures

---

Figure 5-1 BMP Capacity Required by Permittee for 2018 Milestone Compliance .....	70
Figure 5-2 BMP Capacity Required by Permittee for 2021 Milestone Compliance .....	71

# List of Acronyms

---

<b><u>Acronym</u></b>	<b><u>Definition</u></b>
AED	Allowable Exceedance Day
ASCE	American Society of Civil Engineers
Basin Plan	Basin Plan for the Coastal Watersheds of Los Angeles and Ventura Counties
BIOL	Preservation of Biological Habitats of Special Significance Beneficial Use Designation
BMP	Best Management Practice
Caltrans	California Department of Transportation
CASQA	California Stormwater Quality Association
CEDEN	California Environmental Data Exchange Network
CEQA	California Environmental Quality Act
CERCLA	Comprehensive Environmental Response, Compensation, and Liability Act
CFR	Code of Federal Regulations
CIMP	Coordinated Integrated Monitoring Program
City	City of Los Angeles
CML	Compliance Monitoring Location
CMP	Corrugated Metal Pipe
COMM	Commercial and Sport Fishing Beneficial Use Designation
County	County of Los Angeles
CSMP	Coordinated Shoreline Monitoring Plan
CTR	California Toxics Rule
CWA	Clean Water Act
DDT	Dichlorodiphenyltrichloroethane
DP	Dissolved Phosphorus
ED	Exceedance Day
EMC	Event Mean Concentration
ESA	Environmentally Sensitive Area
ESCP	Erosion and Sediment Control Plan
EWMP	Enhanced Watershed Management Program
FC	Fecal Coliform
FIB	Fecal Indicator Bacteria
GIS	Geographic Information System
GM	Geometric Mean
HUC	Hydraulic Unit Code
IBD	International BMP Database
IC/ID	Illicit Connections and Illicit Discharges
IGP	Industrial General Permit
IND	Industrial Service Supply Beneficial Use Designation
IRWMP	Integrated Regional Water Management Plan

<b><u>Acronym</u></b>	<b><u>Definition</u></b>
JG2/JG3	Jurisdictional Groups 2 and 3
L-SWPPP	Local Storm Water Pollution Prevention Plan
LA	Los Angeles
LACDPW	Los Angeles County Department of Public Works
LACFCD	Los Angeles County Flood Control District
LAX	Los Angeles International Airport
LFD	Low-Flow Diversion
LID	Low Impact Development
LRP	Local Resource Program
MAR	Marine Habitat Beneficial Use Designation
MCM	Minimum Control Measure
MG/L	Milligrams per Liter
MIGR	Fish Migration Beneficial Use Designation
MPN	Most Probable Number
MS4	Municipal Separate Storm Sewer System
MUN	Municipal and Domestic Supply Beneficial Use Designation
MWD	Metropolitan Water District of Southern California
MWH	MWH Americas, Inc.
N	Nitrogen
NA	Not Applicable
NAV	Navigation Beneficial Use Designation
NH <sub>3</sub>	Ammonia
NO <sub>3</sub>	Nitrate
NOI	Notice of Intent
NPDES	National Pollutant Discharge Elimination System
NSMBCW	North Santa Monica Bay Coastal Watershed
O&M	Operation and Maintenance
OPTI	Online Project Tracking and Integration System
Permit	Los Angeles Regional Water Quality Control Board Order No. R4-2012-0175
PCBs	Polychlorinated Biphenyls
PIPP	Public Information and Participation Program
POTW	Publically-Owned Treatment Works
QA/QC	Quality Assurance/Quality Control
RAA	Reasonable Assurance Analysis
RARE	Preservation of Rare and Endangered Species Beneficial Use Designation
REC-1	Water Contact Recreation Beneficial Use Designation
REC-2	Noncontact Water Recreation Beneficial Use Designation
Regional Board	Los Angeles Regional Water Quality Control Board
RWL	Receiving Water Limitation
SBPAT	Structural Best Management Practice Prioritization and Analysis Tool

<b><u>Acronym</u></b>	<b><u>Definition</u></b>
SCCWRP	Southern California Coastal Research Project
SHELL	Shellfish Harvesting Beneficial Use Designation
SMB	Santa Monica Bay
SMB EWMP Group	Santa Monica Bay EWMP Group
SMURRF	Santa Monica Urban Runoff Recycling Facility
SPWN	Fish Spawning Beneficial Use Designation
SQMP	Stormwater Quality Management Plan
SUSMP	Standard Urban Stormwater Mitigation Plan
SWAMP	Surface Water Ambient Monitoring Program
SWMM	Stormwater Management Model
SWPPP	Stormwater Pollution Prevention Plan
SWRCB	State Water Resources Control Board
TAC	Technical Advisory Committee
TKN	Total Kjeldahl Nitrogen
TLR	Target Load Reduction
TM	Technical Memorandum
TMDL	Total Maximum Daily Load
TP	Total Phosphorus
TSS	Total Suspended Solids
USEPA	United States Environmental Protection Agency
UV	Ultraviolet
WARM	Warm Freshwater Habitat Beneficial Use Designation
WBPC	Water Body Pollutant Combinations
WERF	Water Environment Research Foundation
WDID	Waste Discharger Identification
WILD	Wildlife Habitat Beneficial Use Designation
WLA	Waste Load Allocation
WMA	Watershed Management Area
WMG	Watershed Management Group
WMP	Watershed Management Plan
WQBEL	Water Quality-Based Effluent Limitation
WRRDA	Water Resources Reform and Development Act of 2014

# Section 1

## Introduction

---

The Santa Monica Bay (SMB) Jurisdictional Groups 2 and 3 (JG2/JG3) Enhanced Watershed Management Program (EWMP) has been developed by the Santa Monica Bay Enhanced Watershed Management Group (SMB EWMP Group), which is comprised of City of Los Angeles, County of Los Angeles, City of Santa Monica, City of El Segundo, and the Los Angeles County Flood Control District (LACFCD). The EWMP is a requirement of the National Pollutant Discharge Elimination System (NPDES) Municipal Separate Storm Sewer System (MS4) Permit Order No. R4-2012-0175 (Permit), which was adopted by the Los Angeles Regional Water Quality Control Board (Regional Board) and became effective on December 28, 2012.

The EWMP has been developed as a result of the EWMP Work Plan, which documented the water quality objectives, priorities, and process for identifying regional projects. The EWMP contains strategies to address the water quality objectives, including the types and locations of distributed and regional best management practices (BMPs) that can be implemented to obtain the required target load reduction in the SMB watershed.

Also as part of the Permit requirements, the SMB EWMP Group developed a Coordinated Integrated Monitoring Plan (CIMP) to monitor the effectiveness of the EWMP and resultant change in water quality (MWH Team B, 2014). The CIMP is intended to serve as a guide for future adaptive management of the EWMP.

This document is organized as follows:

- **Section 1 Introduction** - provides an introduction to the EWMP and describes the applicability of the EWMP, the geographical extent of the watershed, the regulatory framework, and a discussion of the EWMP development process.
- **Section 2 Identification of Water Quality Priorities** –focuses on the identification of water quality priorities for the SMB watershed, including characterization and prioritization of water body pollutants.
- **Section 3 Reasonable Assurance Analysis** – describes the Reasonable Assurance Analysis (RAA), including the modeling system, RAA process overview, and modeling approach.
- **Section 4 Watershed Control Measures** – presents watershed control measures, with a review of institutional and structural BMPs, and concludes with a discussion of non-stormwater discharge control measures.
- **Section 5 EWMP Implementation Schedule** – presents the schedule for EWMP implementation for the watershed.
- **Section 6 Assessment and Adaptive Management Framework** – describes the framework for assessment and adaptive management, addressing topics such as re-characterization of water quality priorities, source assessment re-evaluation, effectiveness of watershed control measures, the adaptive management process, updating the RAA, and compliance reporting.
- **Section 7 EWMP Implementation Costs and Financial Strategy** – reviews the implementation costs and financial strategy associated with the EWMP.

- **Section 8 Legal Authority** -demonstrates that the Permittees have the necessary legal authority to implement the BMPs identified in the EWMP.

### 1.1. APPLICABILITY OF EWMP

The SMB watershed management area (WMA) EWMP Group area falls within the boundaries of JG2/JG3, which are located within the central region of the SMB Watershed. Subwatersheds within the SMB EWMP Group Area include the urbanized Dockweiler and Santa Monica subwatersheds, as well as natural open space located in the Castle Rock, Pulga Canyon, Temescal Canyon, and Santa Monica Canyon subwatersheds. The JG2/JG3 area totals 34,362 acres within the SMB Watershed and **Figure 1-1** illustrates the extent of the SMB EWMP Group Area.

### 1.2. GEOGRAPHICAL SCOPE AND CHARACTERISTICS

The SMB EWMP Group area includes land area that drains into and includes the SMB. However, the geographical scope of the SMB EWMP Group area excludes areas of land totaling 9,124 acres for which the MS4 Permittees do not have jurisdiction, including land owned by the State of California, Caltrans, the United States Government, and an area of the Chevron Facility located in the City of El Segundo. Therefore, with the exclusion of these areas, the SMB EWMP Group area covers 25,238 acres.

Approximately 49 percent of the SMB EWMP Group area is open space, of which approximately 93 percent is located in the northern subwatersheds and approximately 7 percent is located in the Dockweiler subwatershed. The boundary of the SMB, as defined for the National Estuary Program, extends from the Los Angeles/Ventura County line to the northwest, southward to Point Fermin located on the Palos Verdes Peninsula to the southeast. The land area that drains into SMB follows the crest of the Santa Monica Mountains on the north to Griffith Park, then extends south and west across the Los Angeles coastal plain to include the area east of Ballona Creek and north of the Baldwin Hills. South of Ballona Creek the natural drainage is a narrow coastal strip between Playa del Rey and Palos Verdes (Regional Board, 2011). **Figure 1-2** shows the SMB EWMP Group within the SMB Watershed.

According to geographical information system (GIS) data from the Los Angeles County Department of Public Works (LACDPW), approximately 67 percent of the SMB EWMP Group area is pervious, with the large majority of pervious area located in the northern-most subwatersheds of Castle Rock, Pulga Canyon, Temescal Canyon and Santa Monica Canyon. Approximately 95,000 acre-feet of precipitation falls on the watershed in an average year. Approximately one third of that volume becomes runoff. Subwatersheds and their contributing water bodies/tributaries are summarized in **Table 1-1**.

Figure 1-1  
 Santa Monica Bay EWMP Group Area

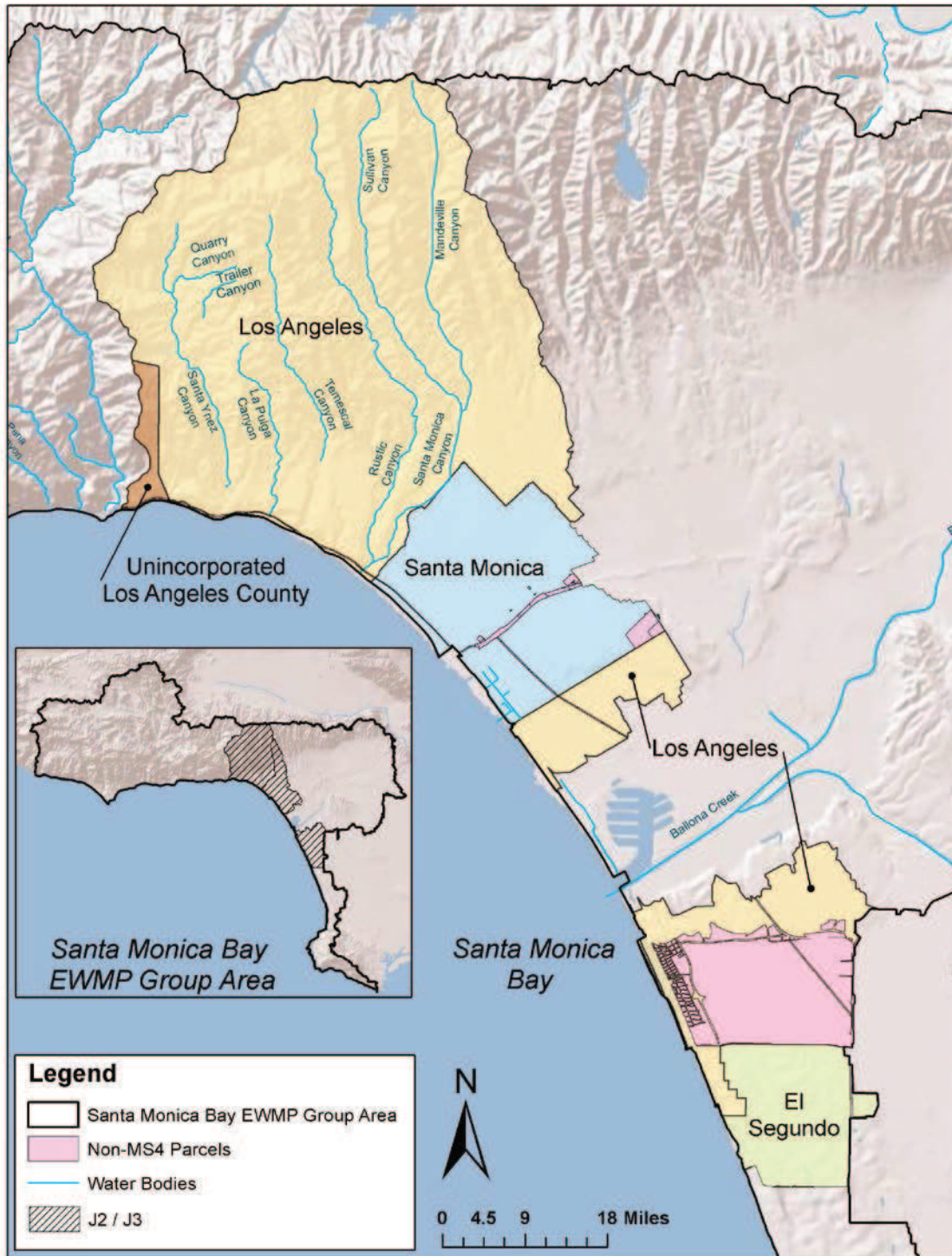
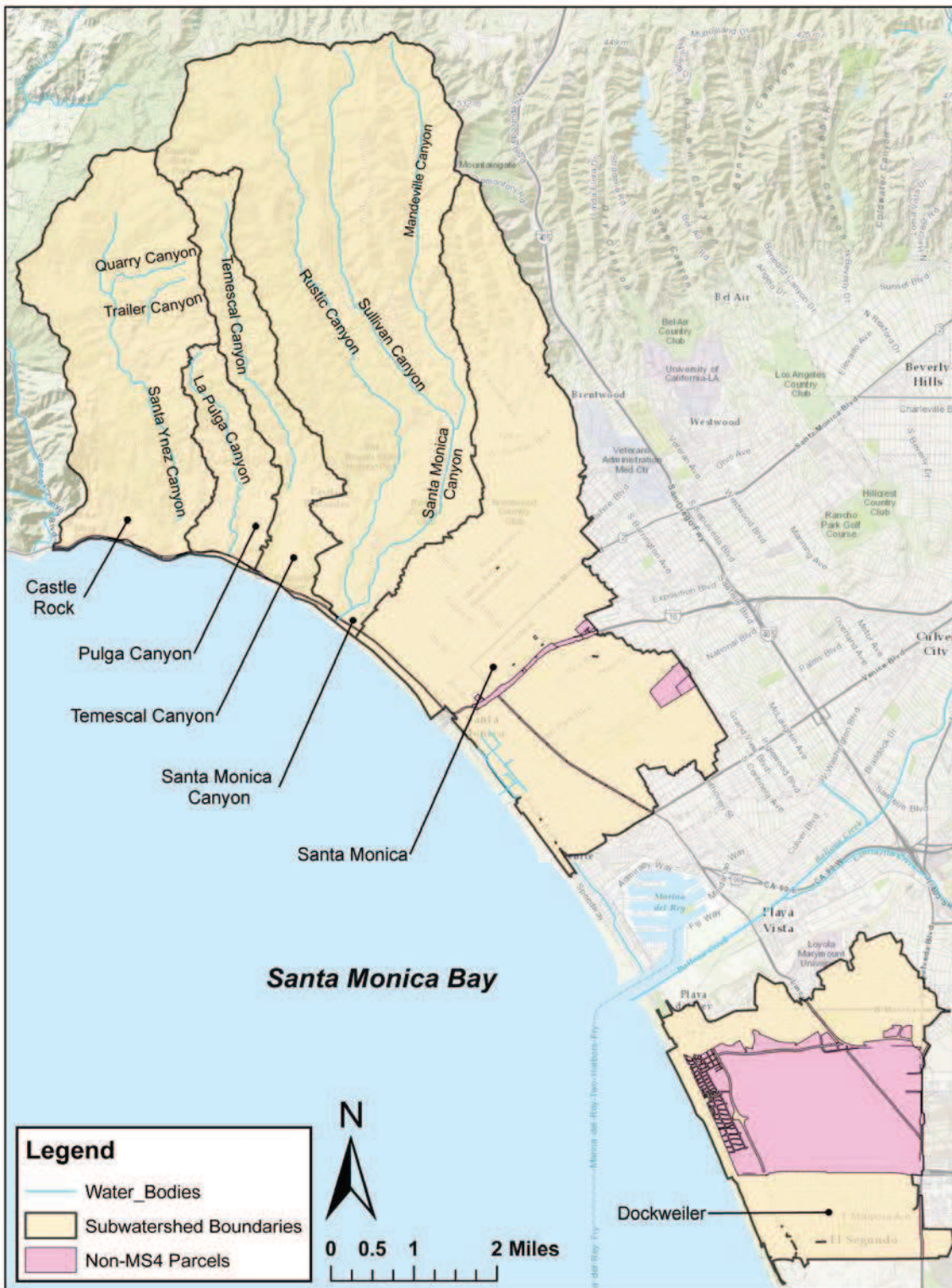

Figure 1-2  
Santa Monica Bay Subwatersheds



**Table 1-1  
Santa Monica Bay EWMP Area Subwatersheds and Associated Water Bodies/Tributaries**

<b>Subwatersheds</b>	<b>Water Body</b>	<b>Water Body/Tributary</b>
Castle Rock	Santa Ynez Canyon	Quarry Canyon Trailer Canyon
Pulga Canyon	La Pulga Canyon	
Temescal Canyon	Temescal Canyon	
Santa Monica Canyon	Santa Monica Canyon	Rustic Canyon Creek Sullivan Canyon Creek Mandeville Canyon Creek
Santa Monica	Santa Monica Bay	
Dockweiler	Santa Monica Bay	

### 1.3. REGULATORY FRAMEWORK

The NPDES MS4 Permit No. R4-2012-0175 (Permit) was adopted on November 8, 2012 by the Regional Board and became effective as of December 28, 2012. The purpose of the Permit is to ensure the MS4s in the County of Los Angeles are not causing or contributing to exceedances of water quality objectives set to protect the beneficial uses in the receiving waters in the Los Angeles region.

#### 1.3.1. MS4 Permit Requirements

The Permit allows Permittees to customize their stormwater programs through the development and implementation of a Watershed Management Program (WMP) or EWMP to achieve compliance with receiving water limitations (RWL) and water quality-based effluent limits (WQBEL). The SMB EWMP Group submitted a notice of intent (NOI) to develop an EWMP in June of 2013 (a revised NOI was submitted in December 2013) to fulfill the requirements of the Permit. This EWMP is consistent with Part VI.C.5-C.8 of the Permit, and:

1. Prioritizes water quality issues resulting from stormwater and non-stormwater discharges from the MS4 to receiving waters within the SMB EWMP Group area;
  - (i) Identifies strategies to implement control measures and BMPs to achieve the outcomes specified in Part VI.C.1.d of the Permit;
  - (ii) Provides a process to modify strategies, control measures, and BMPs as necessary based on analysis of monitoring data in order to ensure that applicable WQBELs, RWLs, and other milestones (as set forth in the EWMP Work Plan) are achieved in the required timeframes; and
2. Provides appropriate opportunity for meaningful stakeholder input, including but not limited to, a permit-wide technical advisory committee.

#### 1.3.2 Relevant Total Maximum Daily Loads

When designated beneficial uses of a particular receiving water body are being compromised by water quality, Section 303(d) of the federal Clean Water Act (CWA) requires identifying and listing that water body as “impaired”. Once a water body has been deemed impaired, a Total Maximum Daily Load (TMDL) must be developed for the impairing pollutant(s). A TMDL is an estimate of the total load of

pollutants from point, non-point, and natural sources that a water body may receive without exceeding applicable water quality standards (with a “factor of safety” included). Once established, the TMDL allocates the loads among current and future pollutant sources to the water body.

The CWA requires that the State Water Resources Control Board and Regional Boards conduct a water quality assessment that addresses the condition of its surface waters (required in Section 305(b) of the CWA) and provides a list of impaired waters (required in CWA Section 303(d)) which is then submitted to the United States Environmental Protection Agency (USEPA) for review and approval. The report integrates the requirements of these two CWA sections and is referred to as the Integrated Report. The 2010 Integrated Report and updated 303(d) list were approved by the State Water Resources Control Board on August 4, 2010 and by the USEPA on October 11, 2011.

The 303(d)-listed water bodies and associated pollutants within the SMB Watershed are summarized in **Table 1-2**.

**Table 1-2**  
**303(d) – Listed Water Bodies in the SMB Watershed**

<b>Water Body</b>	<b>Pollutant Class</b>	<b>Pollutant</b>	<b>Notes</b>
Santa Monica Bay Beaches	Pathogens	Coliform Bacteria	Addressed by Bacteria TMDL
	Pesticides	DDT	Addressed by PCB/DDT TMDL
	Other Organics	PCBs	Addressed by PCB/DDT TMDL
Santa Monica Bay Offshore/Nearshore	Trash	Debris	Addressed by Trash TMDL
	Pesticides	DDT (tissue & sediment)	Addressed by PCB/DDT TMDL
	Other Organics	PCBs (tissue & sediment)	Addressed by PCB/DDT TMDL
	Toxicity	Sediment Toxicity	Addressed by PCB/DDT TMDL
	Miscellaneous	Fish Consumption Advisory	Addressed by PCB/DDT TMDL
Santa Monica Canyon Channel	Metals/Metalloids	Lead	TMDL does not currently exist
	Pathogens	Indicator Bacteria	Addressed by Bacteria TMDL

Notes:

DDT – dichlorodiphenyltrichloroethane

PCBs - polychlorinated biphenyls

The water bodies listed in **Table 1-1** are subject to water quality objectives in the Water Quality Control Plan, Los Angeles Region (Basin Plan) (Regional Board, 1995, Updated 2011) and its Amendments, such as those to implement TMDLs. There are currently five TMDLs in effect for the water bodies within the JG2/JG3 geographical scope as listed in Attachment M of the MS4 Permit. These TMDLs are summarized in **Table 1-3**.

**Table 1-3  
North Santa Monica Bay Coastal Watersheds (NSMBCW) TMDLs**

<b>TMDL Name</b>	<b>Agency</b>	<b>TMDL Effective Date</b>
SMB Beaches (SMBB) Bacteria TMDL, Reconsideration of Certain Technical Matters of the SMBB Bacteria TMDL, Resolution R12-007 <sup>1</sup>	Regional Board	July 2, 2014
SMB TMDL for DDT and PCBs	USEPA	March 26, 2012
SMB Nearshore Debris TMDL, Resolution R10-010	Regional Board	March 20, 2012
SMB Beaches (SMBB) Bacteria TMDL, Dry Weather, Resolution 2002-004 <sup>2</sup>	Regional Board	July 15, 2003
SMB Beaches (SMBB) Bacteria TMDL, Wet Weather, Resolution 2002-022 <sup>2</sup>	Regional Board	July 15, 2003

<sup>1</sup> TMDL revision pending approved by USEPA.

<sup>2</sup> TMDL was revised pursuant to Resolution R12-2007.

**Table 1-4** identifies the applicable WQBELs and/or RWLs established pursuant to TMDLs included in Attachment M of the Permit. The water quality objectives as listed in the Basin Plan are also applicable to water bodies based on the designated beneficial uses. The Trash TMDL final compliance deadline is March 20, 2020. The final compliance deadline for the Bacteria TMDL WQBELs and RWLs has already passed for dry weather and is July 15, 2021 for wet weather.

Grouped RWLs for the SMBB Bacteria TMDL are also expressed in the Permit in terms of allowable exceedance days (AEDs), which vary by season and by Coordinated Shoreline Monitoring Plan (CSMP) monitoring station. These final compliance deadline for Bacteria TMDL, WQBELs and RWLs has already passed for dry weather and will be effective July 15, 2021 for wet weather.

**Table 1-4  
Final Permit RWLs and WQBELs for SMB TMDLs**

Reference	Parameter	Effluent Limitation/ Receiving Water Limitation
SMB Nearshore Debris TMDL	Trash – WQBEL	Zero
	Plastic Pellets – WQBEL	Zero
TMDL for PCBs/DDT (for LA County MS4)	DDT – WQBEL	27.08 g/yr (based on 3-year averaging period) <sup>2</sup>
	PCBs – WQBEL	140.25 g/yr (based on 3-year averaging period)
SMBB Bacteria TMDL	Total coliform (daily maximum) – WQBEL	10,000 Most Probable Number (MPN)/100 mL
	Total coliform (daily maximum), if the ratio of fecal-to- total coliform exceeds 0.1 – WQBEL	1,000 MPN/100 mL
	Fecal coliform (daily maximum) – WQBEL	400 MPN/100 mL
	Enterococcus (daily maximum) – WQBEL	104 MPN/100 mL
	Total coliform (geometric mean <sup>1</sup> ) – WQBEL/RWL	1,000 MPN/100 mL
	Fecal coliform (geometric mean <sup>1</sup> ) – WQBEL/RWL	200 MPN/100 mL
	Enterococcus (geometric mean <sup>1</sup> ) – WQBEL/RWL	35 MPN/100 mL

<sup>1</sup> The reopened 2012 TMDL, which was approved by USEPA, defines this to be a weekly calculated rolling six week geometric mean using five or more sample, starting all calculation weeks on Sunday.

<sup>2</sup> Group load-based WQBELs that apply to all SMB MS4 dischargers; the individual load-based WQBELs for JG2/JG3 MS4 agencies would be an area-weighted fraction of this.

#### 1.4. ENHANCED WATERSHED MANAGEMENT PROGRAM DEVELOPMENT PROCESS

Development of the EWMP for the SMB EWMP Group included four major components:

- 1. Water Quality Priorities:** The identification of water quality priorities was an important first step in the EWMP process. Water quality priorities were defined for individual constituents within a specific water body, termed water body-pollutant combinations (WBPCs). Categories of the WBPCs are defined in the Permit. Priorities were assigned to the WBPCs based on the categorization. The water quality priorities provide the basis for prioritizing implementation activities, as well as the selection and scheduling of BMPs in the Reasonable Assurance Analysis (RAA).
- 2. Watershed Control Measures:** Development of the EWMP required identification of control measures/BMPs, as described in Section 4, expected to be sufficient to meet receiving water and effluent limitations set forth in the MS4 Permit (Regional Board, 2012). BMPs vary in function and type, with each BMP providing unique design characteristics and benefits from implementation. The overarching goal of BMPs in the EWMP is to reduce the impact of stormwater and non-stormwater on receiving water quality.
- 3. Reasonable Assurance Analysis:** A key element of each EWMP is the RAA, which was used to demonstrate “...that the activities and control measures...will achieve applicable WQBELs and/or RWLs with compliance deadlines during the Permit term” (Section C.5.b.iv.(5), page 63). While the Permit prescribes the RAA as a quantitative demonstration that control measures will be effective, the RAA also promotes a modeling process to identify and prioritize potential

control measures to be implemented. The RAA considered the applicable compliance dates and milestones for attainment of the WQBELs and RWLs, and supports BMP scheduling.

4. **Stakeholder Investment:** The EWMP Group has been strongly committed to providing the opportunity for meaningful stakeholder input throughout the development of the EWMP. The EWMP Group participated in monthly Watershed Management Group meetings, designed to facilitate collaboration with all Permittees. Public meetings were held on April 10, 2014, November 20, 2014, and March 19, 2015, to receive feedback from stakeholders on the progress and plans. Stakeholder collaboration will continue throughout implementation of the EWMP.

## Section 2

# Identification of Water Quality Priorities

---

In accordance with the Permit Section IV.C.5(a), water quality priorities have been established for the EWMP. The water quality priorities provide the basis for prioritizing project implementation; selecting and scheduling BMPs; and focusing monitoring activities developed in the CIMP. Details on the development of the water quality priorities are included in the CIMP.

### 2.1. WATER QUALITY CHARACTERIZATION

**Figure 2-1** identifies the receiving waters in the SMB EWMP Group area, as depicted in the Basin Plan (Regional Board, 1995, Updated 2011). Ultimately, all receiving water bodies are tributary to the Santa Monica Bay. **Table 2-1** summarizes the beneficial uses for each water body in the SMB EWMP Group area, as designated in the Basin Plan.

# Identification of Water Quality Priorities

Figure 2-1  
Receiving Waters in the SMB EWMP Group Area



# Identification of Water Quality Priorities

**Table 2-1  
Beneficial Uses of Water Bodies and Coastal Features Designed in the Basin Plan**

Water Body (and Tributaries)	Beneficial Uses													
	MUN <sup>1</sup>	WARM	WILD	RARE	REC-1	REC-2	IND	NAV	COMM	MAR	BIOL	MIGR	SPWN	SHELL
Santa Monica Bay - Nearshore Zone <sup>^</sup>			E	Ee			E	E	E	E	E <sub>n</sub>	Ef	Ef	Ear
La Pulga Canyon <sup>a</sup>			E	Ee			E	E	E	E	E <sub>n</sub>	Ef	Ef	Ear
Temescal Canyon <sup>a</sup>			E	Ee			E	E	E	E	E <sub>n</sub>	Ef	Ef	Ear
Santa Monica Canyon Channel	P*	P	P		Ps	I								
Rustic Canyon Creek	P*	I	E		I	I								
Sullivan Canyon Creek	P*	I	E		I	I								
Mandeville Canyon Creek	P*	I	E		I	I								
Santa Ynez Canyon	P*	I	E	E	Pk	E								
Quarry Canyon <sup>a</sup>	P*	I	E	E	Pk	E								
Trailer Canyon <sup>a</sup>	P*	I	E	E	Pk	E								
Will Rogers Beach			E		E	E		E	E	E			P	E
Santa Monica Beach			E		E	E		E	E	E		E	E <sub>s</sub>	E
Venice Beach			E	E	E	E		E	E	E		E	E <sub>s</sub>	E
Dockweiler Beach			E		E	E	E	E	E	E			P	

**Notes:**

Beneficial Use Designations: **MUN** = Municipal and Domestic Supply; **WARM** = Warm Freshwater Habitat; **WILD** = Wildlife Habitat; **RARE** = Preservation of Rare and Endangered Species; **REC-1** = Water Contact Recreation; **REC-2** = Noncontact Water Recreation; **IND** = Industrial Service Supply; **NAV** = Navigation; **COMM** = Commercial and Sport Fishing; **MAR** = Marine Habitat; **BIOL** = Preservation of Biological Habitats of Special Significance; **MIGR** = Fish Migration; **SPWN** = Fish Spawning; **SHELL** = Shellfish Harvesting

<sup>1</sup> Asterisked MUN designations are designated under State Water Resources Control Board Resolution No. 88-63 (SB 88-63) and Regional Board Resolution No. 89-03 (RB 89-03). Some designations may be considered for exemption at a later date.

P = Potential beneficial use

I = Intermittent beneficial use

E = Existing beneficial use

a = Beneficial use designations apply to all tributaries to the indicated water body, if not listed separately.

e = One or more rare species utilize all bays, estuaries, lagoons and coastal wetlands for foraging and/or nesting

f = Aquatic organisms utilize all bays, estuaries, lagoons, and coastal wetlands, to a certain extent, for spawning and early development. This may include migration into areas which are heavily influenced by freshwater inputs.

k = Public access to reservoir and its surrounding watershed is prohibited by Los Angeles County DPW

s = Access prohibited by LACDPW)

an = Areas of Special Biological Significance (along coast from Latigo Point to Laguna Point) and Big Sycamore Canyon and Abalone Cove Ecological Reserves and Point Fermin Marine Life Refuge.

ar = Areas exhibiting large shellfish populations include Malibu, Point Dume, Point Fermin, White Point and Zuma Beach.

as = Most frequently used grunion spawning beaches. Other beaches may be used as well.

<sup>^</sup> = Nearshore is defined as the zone bounded by the shoreline or the 30-foot depth contours, whichever is further from the shoreline. Longshore extent is from Rincon Creek to the San Gabriel River Estuary.

## Identification of Water Quality Priorities

### 2.2. WATER BODY-POLLUTANT PRIORITIZATION

Based on the water quality characterization, the WBPCs were classified into one of three categories, in accordance with Section IV.C.5(a)ii of the Permit. **Table 2-2** summarizes the criteria for each category, as defined by the Permit. **Table 2-3** presents the WBPCs for the SMB EWMP.

**Table 2-2**  
**Description of Water Body-Pollutant Prioritization Categories**

Category	WBPC Description
1	Category 1 (highest priority) are defined in the Permit as “water body-pollutant combinations for which water quality-based effluent limitations and/or receiving water limitations are established in Part VI.E and Attachments L through R [of the Permit].”
2	Category 2 (high priority) are defined as “pollutants for which data indicate water quality impairment in the receiving water according to the State’s Water Quality Control Policy for Developing California’s Clean Water Act Section 303(d) List (State Listing Policy) and for which MS4 discharges may be causing or contributing to the impairment.”
3	Category 3 (Medium Priority) designations are to be applied to “constituents that are not 303(d)-listed, but which exceed applicable receiving water limitations contained in the Permit and for which MS4 discharges may be causing or contributing to the exceedance.”

**Table 2-3**  
**Water Body Pollutant Prioritization<sup>1</sup>**

Category	Water Body	Pollutant	Compliance Deadline
1	SMB Beaches	Summer dry weather bacteria	7/15/2006 (Final: Single sample summer AEDs)
	SMB Beaches	Wet weather bacteria	7/15/2009 (Interim: 10% single sample ED reduction) 7/15/2013 (Interim: 25% single sample ED reduction) 7/15/2018 (Interim: 50% single sample ED reduction) 7/15/2021 (Final: Single sample AED) 7/15/2021 (Final: Geometric Mean [GM])
	SMB Beaches	Winter dry weather bacteria	7/15/2009 (Final: Single sample winter AEDs) <sup>2</sup>
	SMB Offshore/ Nearshore	Debris	3/20/2016 (20% load reduction) 3/20/2017 (40% load reduction) 3/20/2018 (60% load reduction) 3/20/2019 (80% load reduction) 3/20/2020 (100% load reduction)
	SMB	DDTs	Compliance to be demonstrated through monitoring and adaptive management process <sup>3</sup>
	SMB	PCBs	Compliance to be demonstrated through monitoring and adaptive management process <sup>3</sup>
2	Santa Monica Canyon Channel	Lead	NA
	Santa Monica Canyon Channel	Indicator bacteria	NA
3	None	None	None

<sup>1</sup> Listed in order of compliance deadline, interim and final are included

<sup>2</sup> Compliance date per 2013 reopened TMDL, which is not yet effective (i.e., USEPA and Office of Administrative Law approval is pending).

<sup>3</sup> Although the TMDL lacks a formal compliance schedule for the WQBEL, the TMDL Executive Summary does state, “The time frame for attainment of the TMDL targets for the rest of Santa Monica Bay (other than the Palos Verdes shelf) is 11 years for DDT and 22 years for PCBs.”

---

## Identification of Water Quality Priorities

---

As part of the adaptive management process, categorization of WBPCs may be adjusted based on data obtained from monitoring, source evaluations, and BMP implementation. Data collected as part of the approved CIMP may result in future Category 3 designations in instances when RWLs are exceeded and MS4 discharges are identified as contributing to such exceedances. Under these conditions, the appropriate agencies will adhere to Section VI.C.2.a.iii of the Permit. Additionally, an investigation has confirmed that plastic pellets are not a source of pollutants and are not currently used, stored, handled or transported in the SMB area. **Appendix G** shows a confirmation of these results.

### 2.3. SOURCE ASSESSMENT

The following data sources were reviewed as part of the source assessment for bacteria, lead, and DDT/PCBs in the SMB CML analysis regions:

- Findings from the Permittees' Illicit Connections and Illicit Discharge (IC/ID) Elimination Programs;
- Findings from the Permittees' Industrial/Commercial Facilities Programs;
- Findings from the Permittees' Development Construction Programs;
- Findings from the Permittees' Public Agency Activities Programs;
- TMDL source investigations;
- Watershed model results;
- Findings from the Permittees' monitoring programs, including but not limited to TMDL compliance monitoring and receiving water monitoring; and
- Any other pertinent data, information, or studies related to pollutant sources and conditions that contribute to the highest water quality priorities.

Because sources of pollutants for the various water bodies within the SMB watershed are essentially identical, the following source assessment is broken down by pollutant.

#### 2.3.1. Indicator Bacteria

Wet weather runoff event mean concentrations (EMCs) for fecal coliform, based on the Southern California Coastal Water Research Project (SCCWRP) land use data for the Los Angeles region (Stein *et al*, 2007), indicate that the highest concentrations are expected from agricultural land uses, followed by commercial and educational, single family residential, multi-family residential, open space, industrial, and transportation. The SCCWRP study also found that in some cases, the levels of fecal indicator bacteria at the recreational (horse) and agricultural land use sites were as high as those found in primary wastewater effluent in the United States. Tiefenthaler *et al* (2011) also found that horse stable sites contributed to significantly higher wet weather EMCs than other land use types.

The SMBB Bacteria TMDL for both dry and wet weather was the first bacteria TMDL adopted by the Regional Board in the State of California. The SMBB Bacteria TMDL was recently opened for reconsideration, although the source assessment was not part of this update. As a result, the general findings from the original source assessment remain unchanged. These findings are summarized in the 2012 Basin Plan Amendment for the reopened SMBB Bacteria TMDL (Attachment A to Resolution No. R12-007):

*“With the exception of isolated sewage spills, dry weather urban runoff and stormwater runoff conveyed by storm drains and creeks is the primary source of elevated bacterial indicator densities to SMB beaches. Limited natural runoff and groundwater may also potentially contribute to elevated bacterial indicator densities during winter dry weather” (Regional Board, 2012).*

---

## Identification of Water Quality Priorities

---

The SMBB Bacteria TMDL source assessment maintains that dry weather and stormwater runoff is the primary source of elevated bacterial concentrations at SMB beaches. Although definitive information regarding the specific sources of bacteria within the watershed is not presented, speculation provided in the Regional Board dry weather staff report provides some insight into possible sources:

*“Urban runoff from the storm drain system may have elevated levels of bacterial indicators due to sanitary sewer leaks and spills, illicit connections of sanitary lines to the storm drain system, runoff from homeless encampments, illegal discharges from recreational vehicle holding tanks, and malfunctioning septic tanks among other things. Swimmers can also be a direct source of bacteria to recreational waters. The bacteria indicators used to assess water quality are not specific to human sewage; therefore, fecal matter from animals and birds can also be a source of elevated levels of bacteria, and vegetation and food waste can be a source of elevated levels of total coliform bacteria, specifically”* (Regional Board, 2002).

The 2010-2011 and 2011-2012 Los Angeles County Municipal Stormwater Permit Individual Reports<sup>1</sup> for the JG2/JG3 agencies report that both sanitary sewer overflows and IC/ID, while eliminated shortly after being reported, do sometimes occur in those jurisdictions. The 2011-2012 Annual Report for the City of Santa Monica also indicates that overspray from irrigation systems and hosing down of hardscapes contribute dry weather runoff, although this flow is diverted at or near all its outfalls, with low diversions in operation.

The 2011-2012 Santa Monica Bay MS4 Annual Report (City of Los Angeles Environmental Monitoring Division, 2012) states that high bacterial levels measured at the Santa Monica Canyon SMB 2-7 monitoring site have been attributed, at least partially, to stagnant ponded water which attracts wildlife. It should be noted that the City and LACFCDD have worked together to coordinate frequent draining of the pond to prevent it from becoming a major source of pollution.

Additionally, information on non-MS4 sources of surf zone bacteria were provided by the City of Malibu, based on a comprehensive review of Southern California published literature, as part of comments on the reopened Bacteria TMDL (City of Malibu, 2012):

*“A number of recent Santa Monica Bay studies have further identified and confirmed natural (non-anthropogenic) sources of fecal indicator bacteria (FIB) including plants, algae, decaying organic matter, beach wrack and bird feces – implicating these as potentially significant contributors to exceedances (Imamura et al 2011, Izbicki 2012b). Beach sands, sediments and beach wrack have been shown to be capable of serving as reservoirs of FIB, possibly by providing shelter from ultra violet (UV) inactivation and predation by allowing for regrowth (Imamura et al 2011, Izbicki et al 2012b, Lee et al 2006, Ferguson et al 2005, Grant et al 2001, Griffith 2012, Litton et al 2010, Phillips et al 2011, Jiang et al 2004, Sabino et al 2011, and Weston Solutions 2010). In fact, enterococci include non-fecal or “natural” strains that live and grow in water, soil, plants and insects (Griffith, 2012). Thus, elevated levels of enterococci in water could be related to input from natural sources. The phenomenon of regrowth of FIB from either anthropogenic or natural sources has been suggested by several studies as a possible source of beach bacteria exceedances (Griffith 2012, Litton et al 2010, Weston Solutions 2010, Izbicki et al 2012b, Weisberg et al 2009).”*

Other sources of bacteria during wet weather are anticipated to include other non-MS4 permitted stormwater discharges such as Industrial General Permit sites, Construction General Permit sites, Phase II

---

<sup>1</sup> The available Annual Reports were reviewed for 2010-2011 and 2011-2012.

---

## Identification of Water Quality Priorities

---

MS4 Sites (e.g., college campuses), State/Federal owned lands, non-MS4 open space areas such as wildlife habitat, and Caltrans.

### 2.3.2. DDT and PCBs

As stated previously, limited data are available characterizing DDT and PCBs within SMB, particularly since direct discharges of these pollutants from publically owned treatment works (POTWs) have ceased. The largest concentration of DDT and PCBs within SMB is contained within the Palos Verdes shelf, which is being addressed by the USEPA as a Comprehensive Environmental Response Compensation and Liability (CERCLA) site. Loadings from the shelf to the bay are large and have been well characterized (USEPA, 2012).

With respect to stormwater, the TMDL does not specifically characterize MS4 loadings, though it does recognize that “*DDT and PCBs are no longer detected in routine stormwater sampling from Ballona Creek or Malibu Creek.*” However, the TMDL also states that current detection limits used to analyze DDT and PCB concentrations are too high to appropriately assess the water quality. Stormwater inputs are assumed to come from urban areas, as the TMDL specifically states that rural areas in NSMBCW are not likely to be a major source of PCBs or DDT (USEPA, 2012).

No other data or source information is available at this time. Once three years of water quality data are collected under the CIMP and evaluated consistent with the recommendations by USEPA in the TMDL to utilize a three-year averaging period<sup>2</sup>, then further source assessment will be considered and the categorization and prioritization of PCB and DDTs as MS4-related pollutants of concern will be reevaluated. Therefore DDT and PCBs are not included in the WBPC evaluation for RAA compliance at this time.

### 2.3.3. Lead

While the available Annual Reports do not indicate a clear source of lead in this subwatershed, the Regional Board Final Staff Report for the TMDL for Metals in Ballona Creek<sup>3</sup> states that urban runoff, or the wash-off of pollutant loads accumulated on the land surface, is likely a substantial source of metals during both wet and dry weather (Regional Board, 2005). Indirect atmospheric deposition was estimated to account for 19% of the typical annual load for lead in the Ballona Creek Watershed (Regional Board, 2005). Wet weather EMCs for lead, based on the Los Angeles County EMC dataset, show that the highest concentrations are expected from agricultural land uses, followed in order by industrial, commercial, high density single family residential, and transportation, multi-family residential, educational, and open space land uses (Geosyntec Consultants, 2012). Other Los Angeles region land use studies have found that high density single family residential has the highest EMCs, followed by industrial and commercial land uses (Stein *et al* 2007). These potential sources will be evaluated for BMP implementation as part of the RAA.

---

<sup>2</sup> The three-year averaging period is recommended in the USEPA TMDL in Section 8.2, which reads, “We recommend that stormwater waste load allocations be evaluated based on a three year averaging period” (USEPA, 2012). Additionally, Permit Attachment M states that compliance with the PCB and DDT waste load allocations shall be determined based on a three-year averaging period.

<sup>3</sup> Although the Ballona Creek Metals TMDL is not applicable to the Santa Monica Bay Watershed, the staff report describes sources which could be applicable to all urban watersheds.

# Section 3

## Reasonable Assurance Analysis

---

An important component of the SMB EWMP is the RAA. The RAA is a process used to demonstrate that institutional and structural control measures are expected to be sufficient for achieving applicable WQBELs and/or RWLs having compliance deadlines within the Permit term. In addition to using the RAA as a means for determining the efficacy of existing and potential control measures, the RAA also facilitates the selection of BMPs as well as the prioritization of BMP implementation. While the methodology of the RAA evolved over the course of the EWMP development, the RAA approach described herein is consistent with the applied methodology and “RAA Guidelines” as issued by the Regional Board.

### 3.1. MODELING SYSTEM

The RAA approach leverages the strengths of the publicly-available, Permit-approved, GIS-based model already developed for the region: the Structural BMP Prioritization and Analysis Tool (SBPAT). The rationale for utilization of this model for the RAA is described herein.

SBPAT is a public domain, “open source,” GIS-based water quality analysis tool intended to: 1) facilitate the prioritization and selection of BMP project opportunities and technologies in urbanized watersheds; and 2) quantify benefits, costs, variability, and potential compliance risk associated with stormwater quality projects. The decision to use SBPAT for the SMB EWMP RAA (in the manner described herein) is based on the model capabilities and the unique characteristics of the SMB, specifically:

- **Modeling of SMB hydrologic and watershed processes** – SBPAT utilizes the USEPA’s Stormwater Management Model (SWMM) as the hydrologic engine, and SBPAT has been calibrated using local rainfall and SMB stream flow gauges. Calibration results confirm the model’s ability to predict stormwater runoff volumes on an annual basis.
- **SMB pollutants of concern and their compliance metric expression** – SBPAT has been utilized for planning applications related to Bacteria TMDL compliance (and specifically exceedance-day predictions, based on SMB criteria), including a demonstrated linkage of load reduction to exceedance days.
- **Availability of new open space water quality loading data** – Recently-developed EMC data are consistent with SBPAT and were also updated to reflect new data developed in SMB as part of this RAA development effort.
- **Capability to conduct opportunity and constraints investigations** – SBPAT is capable of supporting structural BMP placement, prioritization, and cost-benefit quantification, and has been applied for such purposes previously in the SMB EWMP Group area and other nearby SMB CML analysis regions.
- **Characterization of water quality variability** – SBPAT is capable of quantifying model output variability and confidence levels, which is a component of the Regional Board’s RAA Guidance
- **Quantification of both structural and non-structural BMPs, and demonstration of compliance at both interim and final compliance dates** – SBPAT’s modeling framework is compatible with methods for addressing non-structural BMPs and provides quantitative results for multiple BMP phasing milestones.

Data used for the quantification/analysis module include both fixed and stochastic parameters. The model utilizes land use based EMCs, USEPA SWMM, USEPA/American Society of Civil Engineers/Water

Environment Research Foundation (USEPA/ASCE/WERF) International BMP Database (IBD) water quality concentrations, watershed/GIS data, and a Monte Carlo approach (relying on repeated random sampling) to quantify water quality benefits and uncertainties. The flow of model data is illustrated in the process flow diagram provided in **Figure 3-1**.

**Figure 3-1**  
**Structural BMP Prioritization and Analysis Tool (SBPAT)**

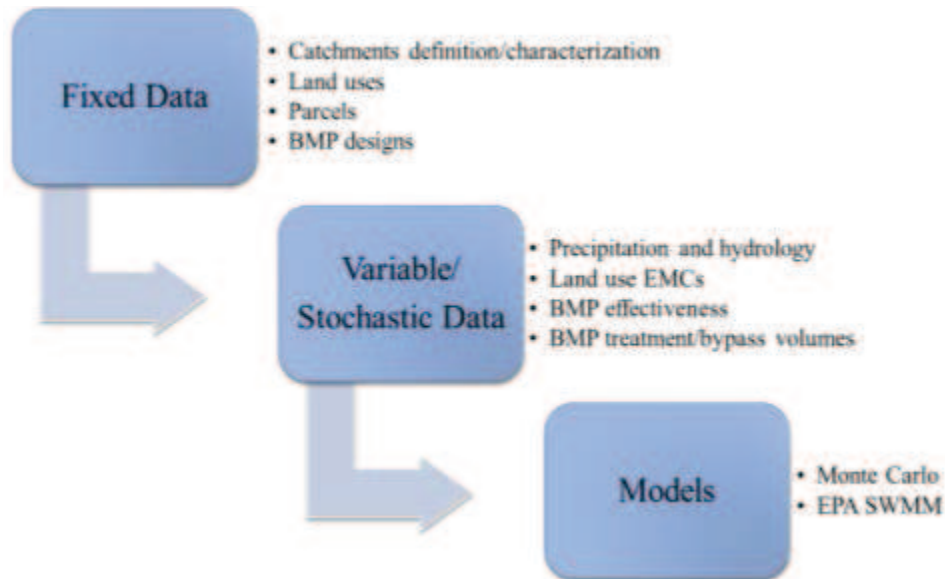

SBPAT integrates Monte Carlo methods for random sampling analysis. Model simulations are run 20,000 times to calculate a distribution of outcomes that can support the definition of confidence levels and quantify variability. Consistent with the SBPAT usage, Monte Carlo methods are typically used in physical and mathematical problems and are most suited for applications when it is difficult to obtain a closed-form expression or when a deterministic algorithm is not desired. A schematic of SBPAT's Monte Carlo process is shown on **Figure 3-2**. Model documentation, as well as links to related technical articles and presentations, can be found on-line at [www.sbp.net](http://www.sbp.net).

**Figure 3-2**  
**Structural BMP Prioritization and Analysis Tool Monte Carlo Methodology**

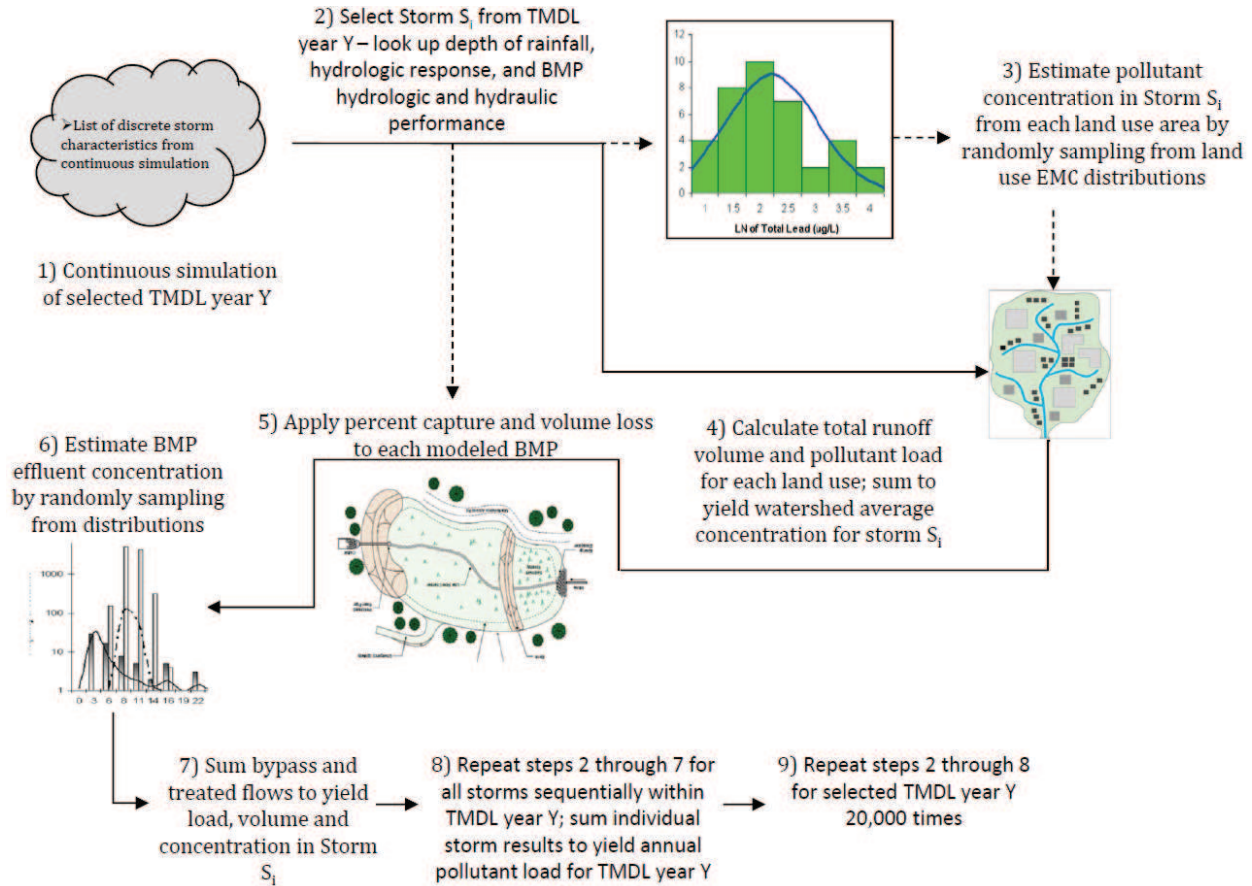

### 3.2. RAA PROCESS OVERVIEW

This section describes an overview of the RAA process. Model selection, data inputs, critical condition selection (90<sup>th</sup> percentile year), calibration performance criteria, and output types have been selected for consistency with the Regional Board RAA Guidance Document (Regional Board, 2014).

#### 3.2.1. Reasonable Assurance Analysis Approach - Dry Weather

Demonstrating reasonable assurance of compliance for the SMB Beaches Bacteria TMDL requires an accounting of many factors that cannot be modeled accurately based on urban runoff processes alone (Thoe *et al*, 2015). This is true despite the extensive summer-dry and winter-dry weather beach-specific monitoring datasets that are available. Therefore, to perform the SMB RAA for dry weather, a semi-quantitative methodology has been developed. This method was developed to follow a permit compliance structure in order to demonstrate how MS4 discharges could or could not be causing or contributing to receiving water exceedances at the beaches. Because fecal indicator bacteria (FIB) are considered the “controlling” pollutants of concern during dry weather in the SMB EWMP Group area (i.e., if MS4 discharges are compliant for bacteria during dry weather, then they will be compliant for all TMDL and 303(d) pollutants during dry weather), the methodology was developed to focus on bacteria. The following criteria form the proposed dry weather RAA methodology. If one criterion is met for each CSMP compliance monitoring location (CML), then reasonable assurance is considered to be

demonstrated. This methodology was presented to Regional Board staff on April 9, 2014, and verbal feedback received at the time was supportive. The RAA methodology addressing FIB consists of:

- A dry weather low flow diversion or infiltration system is located at the CML. To meet this criterion, any such system should have records to show that it is consistently operational, well maintained, and properly sized so that it is effectively eliminating all freshwater surface discharges to the surf zone during year-round dry weather days.
- There are no MS4 outfalls owned by the SMB EWMP Group agencies within the CML's drainage area; therefore, MS4 discharges could not be contributing to pollutant concentrations at the CML.
- The allowed dry weather (summer and winter) single sample exceedance days are based on an antidegradation approach at the CML. If so, this is a result of the Regional Board's TMDL analysis, which found that existing water quality conditions at this CML are acceptable and to be maintained (i.e., no exceedance day reduction needed).
- There are no non-stormwater MS4 outfall discharges within the CML's drainage area. For this criterion to be met, supporting records from the non-stormwater outfall screening program should be supplied.

### 3.2.2. RAA Approach – Wet Weather

The wet-weather RAA process generally consists of the following steps:

- Identify WBPCs for which the RAA will be performed;
- Identify the MS4 service area (exclude lands of agencies not party to this EWMP such as Federal land, State land, etc.);
- For each modeled CML analysis region<sup>4</sup> (**Figure 3-3**), develop target load reductions (TLRs) for 90<sup>th</sup> percentile year based on Permit requirements and Regional Board guidance;
- Identify structural and non-structural BMPs that either were implemented after applicable TMDL effective dates or are planned for implementation in the future;
- Evaluate the performance of these BMPs in terms of annual pollutant load reductions;
- Compare these estimates with the TLRs; and
- Revise the BMP implementation scenario until targets are met.

TLRs represent a numerical expression of the Permit compliance metrics (e.g., bacteria AEDs for wet weather) that can be modeled and can serve as a basis for confirming, with reasonable assurance, that implementation of the proposed BMPs will result in attainment of the applicable WQBELs and RWLs in the Permit.

---

<sup>4</sup> SBPAT input files represent the following CML analysis regions under different IDs: Modeled 2-05 represents 2-06, modeled 2-06 represents 2-05, modeled 2-04\_2-06 represents 2-04\_2-05, and modeled 2-05\_2-07 represents 2-06\_2-07. CML analysis region results were post-processed and attributed to the correct CML analysis region.

Figure 3-3  
Modeled Analysis Regions within the SMB EWMP Group Area

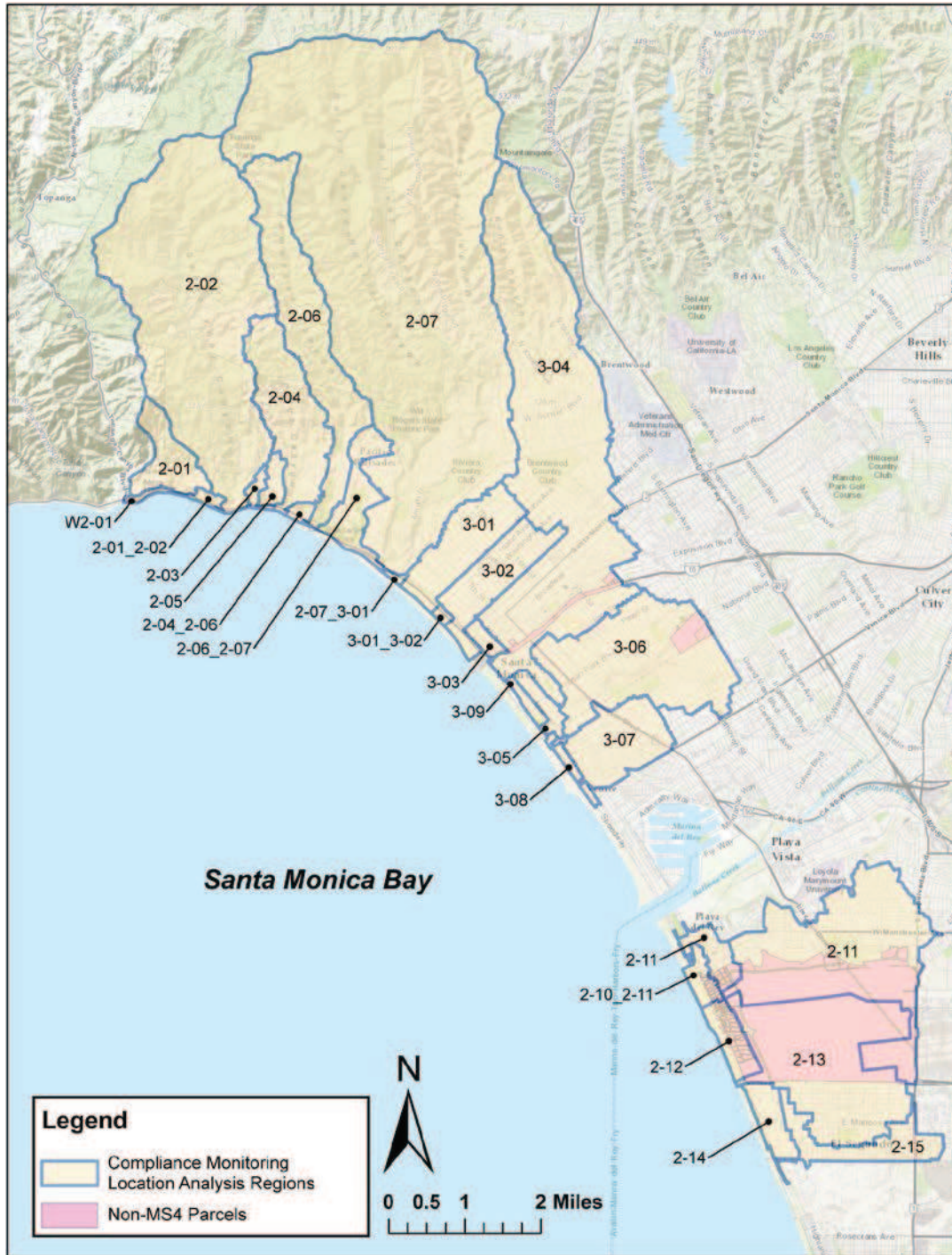

### 3.2.3. Methods to Identify and Prioritize BMP Opportunities

In order to demonstrate reasonable assurance, BMP opportunities were identified in a prioritized manner. Prioritization was based on cost (low cost BMPs were prioritized highest); BMP effectiveness for the pollutants of concern (BMPs that had greater treatment efficiency for the pollutants of concern in a particular analysis region were prioritized higher than other BMPs); and implementation feasibility (as determined by a desktop screening evaluation). In general, non-structural BMPs were prioritized over structural BMPs due to their lower relative cost. Next, structural BMPs were identified that would result in the least cost per load removed, which was accomplished by targeting land uses with the highest pollutant loads for bacteria.

The RAA was performed according to the following steps:

- Assume non-modeled non-structural BMP load reduction (2.5-7.5 percent of baseline pollutant load);
- Calculate public retrofit incentives (e.g., downspout disconnects) and redevelopment load reductions;
- Calculate load reductions attributable to anticipated new permit compliance activities of non-MS4 entities (e.g., Industrial General Permit holders and Caltrans);
- Calculate planned and proposed regional/centralized BMP load reductions based on existing plans and parcel screening analysis; and
- Meet the TLR by backfilling the remaining load reduction with specific regional/centralized BMP projects or distributed BMPs assumed treat a percentage of developed land uses.

### 3.3. MODELING APPROACH

This section discusses the modeling approach, including the general BMP planning objectives, methods used to identify and prioritize BMP opportunities, and inputs and assumptions for the modeled non-structural and structural (regional, centralized, and distributed) BMPs.

#### 3.3.1. BMP Objectives

The primary objectives of the non-structural and structural BMPs are to meet the TLRs in each CML analysis region in order to demonstrate reasonable assurance that compliance with the TMDL WQBELs and RWLs from the Permit will be achieved. Additional goals include reduction of other pollutants to downstream waterbodies, decreased reliance on potable water and replacement with non-potable water for irrigation due to on-site harvest/use and infiltration basin projects, increase in groundwater recharge due to infiltration, and reduction in dry weather runoff.

#### 3.3.2. Non-Structural BMPs

Analyzed non-structural BMPs were categorized as follows. Specific model inputs for modeled non-structural BMPs, including redevelopment, public retrofit incentives, and non-MS4 parcels/areas are summarized in tabular format along with model inputs for distributed green streets BMPs in Section 3.

#### 3.3.3. Non-Modeled Non-Structural BMPs

Non-structural BMPs that were not modeled include a combination of bacteria-targeted, wet weather source control BMPs such as pet waste controls (ordinance, signage, education/outreach, mutt mitts, etc.), human waste source tracking and remediation (e.g., homeless controls, leaking sewer investigations, etc.),

enhanced street sweeping (e.g., 100 percent vacuum sweepers, increased frequency, etc.), increased catch basin and storm drain cleaning, and other new or enhanced non-structural BMPs that target the pollutants addressed in this EWMP. A combined credit of 2.5 – 7.5 percent load reduction (assuming a mean of 5 percent) was applied for all pollutants to represent the cumulative benefit from all non-modeled non-structural BMPs.

### 3.3.4. Modeling Redevelopment Projects

Beginning in 2001, redevelopment projects were required by the Permit (via the Standard Urban Stormwater Management Program SUSMP) to incorporate stormwater treatment BMPs if a project size exceeded specified thresholds. The 2012 MS4 Permit established new criteria for redevelopment projects, requiring certain sized projects to capture, retain, or infiltrate the 85<sup>th</sup> percentile design storm or the 0.75-inch design storm, whichever is greater, via the implementation of LID BMPs. To account for these redevelopment requirements, BMPs were modeled in SBPAT assuming land use-specific annual redevelopment rates for projects that triggered former SUSMP requirements or will trigger the Permit’s LID BMP requirements (**Table 3-1**). Assumed rates were based on redevelopment data collected in the Los Angeles region.

**Table 3-1  
Assumed Annual Redevelopment Rates**

Land Use	Annual Redevelopment Rate (% of total land use area)
Residential	0.18
Commercial	0.15
Industrial	0.34
Education	0.16
Transportation	2.7

The rates for redevelopment rates across two distinct time periods consist of:

- **TMDL Effective Date to 2015:** The SUSMP requirements, based on the 2001 MS4 Permit, were assumed to be implemented over this period as flow-through media filters at a 0.2 in/hr design intensity (LACDPW, 2002).
- **2015 to Final Compliance Deadline (2021):** The 2012 MS4 Permit post-construction requirements were assumed to be implemented over this period as 50 percent biofiltration and 50 percent bioretention. Biofiltration (bioretention with underdrains) were modeled using bioswale BMP types (to account for a small amount of volume reduction) with bioretention effluent EMCs and sized to treat 150 percent of the 1-year, 1-hour design storm (approximately 0.3 in/hr)<sup>5</sup> because flow-through systems do not retain all the design storm volume on site, while bioretention units were sized to retain 100 percent of the 85<sup>th</sup> percentile, 24-hour design storm depth, calculated as the mean for each CML analysis region.

2015 is used as a transition date since the LID post-construction requirements from the 2012 MS4 Permit are required to be in full effect via local LID ordinances by this time.

<sup>5</sup> 150% of the 1-year, 1-hour design storm was used per Section VI.D.7.c.iii of the Permit.

In order to estimate load reductions associated with these redevelopment BMPs, the land use percentages shown in **Table 3-1** were multiplied by the respective land use areas in each analysis region, resulting in an assumed area treated by LID BMPs each year. This area was multiplied by the applicable number of years during each time period noted above, since new BMPs are assumed to be implemented each year. The total land use area assumed to be redeveloped for each analysis region was then modeled as being treated by the BMPs described above and the total load reduction was quantified.

### 3.3.5. Modeling Public Retrofit Incentives

There are a variety of programs directed at incentivizing the public to decrease the amount of stormwater runoff from their property, specifically via downspout disconnects. Public incentives for retrofitting existing development through the downspout disconnection program, was modeled as bioswales sized to a design storm intensity of 0.2 in/hr. Assumptions were: 1) 10 percent of all single family residential areas would be converted to disconnected downspout systems over the time period of 2015 (EWMP implementation start date) to 2021 (TMDL final compliance deadline) and 2) based on GIS analysis, 38 percent of the single family residential area consists of rooftops that can be effectively disconnected. Therefore, 3.8 percent of all single family residential neighborhoods were modeled as being treated by bioswales in order to account for public retrofit incentive programs.

### 3.3.6. Modeling Inspection of Non-MS4 Permitted Parcels or Areas

SBPAT was used to quantify the load reduction in runoff from non-MS4 areas assuming that regulated parcels/areas would be in compliance with the NPDES Statewide Stormwater Permit Waste Discharge Requirements (WDRs) from State of California Department of Transportation (Order No. 2012-0011-DWQ, NPDES No. CAS000003) and the California NPDES General Permit for Stormwater Discharges Associated with Industrial Activities (Industrial General Permit [IGP], Order 2014-0057-DWQ). Load reduction was obtained from these areas by simulating treatment plants sized to treat the IGP's design storm requirement, the 85<sup>th</sup> percentile, 24-hour storm event (0.2 in/hr), with an effluent concentration set equal to the water quality standard. For fecal coliform, 400 MPN/100mL was used. A default diversion rate of 10,000 cfs was assumed for each treatment plant, intended to simulate the capture of all runoff volume from the 85<sup>th</sup> percentile event.

### 3.3.7. Modeling Distributed Green Street BMPs

Distributed BMPs, including green streets, were modeled by assuming 25 percent of the MS4 area can be treated in the right-of-way, and this would be met by 50/50 use of biofilters and bioretention. Biofilters were sized to 150 percent of the 85<sup>th</sup> percentile, 24-hour design storm (0.3 in/hr) consistent with the Permit's post-construction sizing requirements for flow-through systems, while bioretention units were sized to 100 percent of the 85<sup>th</sup> percentile, 24-hour design storm depth, calculated as the mean for each CML analysis region. Biofilters were modeled using bioswale volume reduction and bioretention effluent EMCs. Distributed BMPs were applied at levels unique to each CML analysis region, based on need, after accounting for load reductions attributable to non-structural and regional/centralized BMPs. Furthermore, BMPs were applied by assuming treatment of stormwater from CML analysis region-specified percentages of single family and commercial land use areas and CML analysis region-specified percentages of multi-family land use areas, until TLRs are met. These land use and BMP type combinations were chosen based on their ability to result in maximum bacterial load reduction.

Specific model inputs for public retrofit incentives, redevelopment, and distributed BMPs are summarized in **Table 3-2** and **Table 3-3**. Model input for quantifying load reductions attributable to compliance with non-MS4 permits are summarized in **Table 3-4**.

Table 3-2  
 Redevelopment, Public Retrofit Incentives, and Distributed Green Street BMP Model Assumptions

Implementation Level	BMP Type	Design Storm (in/hr)	Longitudinal Slope (ft/ft)	Manning's n (-)	Hydraulic Residence Time (min)	Water Quality Flow Depth (in)	Effective Retention Depth (in)	Infiltration Rate (in/hr)
Redevelopment (2003-2015)	Media Filter	0.2	-	-	-	-	-	-
	Biofilters <sup>1</sup>	0.3	0.03	0.25	10	4	2	Based on CML analysis region-specific soil type
Redevelopment (2015-2021)	Bioretention	Varies by CML analysis region, see <b>Table 3-3</b>	-	-	-	-	12	0.15
	Bioswales representing downspout disconnects	0.2	0.03	0.25	10	4	2	Based on CML analysis region-specific soil type
Distributed Green Street BMPs (2015-2021)	Biofilters <sup>1</sup>	0.3	0.03	0.25	10	4	2	Based on CML analysis region-specific soil type
	Bioretention	Varies by CML analysis region, see <b>Table 3-3</b>	-	-	-	-	12	0.15

<sup>1</sup> Modeled as bioswales using bioretention effluent EMCs

Table 3-3  
CML Analysis Region-Specific 85<sup>th</sup> Percentile, 24-Hour Design Storm Depths

CML Analysis Region	Design Storm (in)	CML Analysis Region	Design Storm (in)	CML Analysis Region	Design Storm (in)
West of 2-01	0.82	SMB-2-07	1.11	SMB-3-07	1.06
SMB-2-01	0.86	Between 2-07 and 3-01	0.89	SMB-3-08	1.04
Between 2-01 and 2-02	0.82	SMB-3-01	0.98	SMB-2-10	0.98
SMB-2-02	1.04	Between 3-01 and 3-02	0.95	Between 2-10 and 2-11	0.96
SMB-2-03	0.84	SMB-3-02	1.01	SMB-2-11	1.03
SMB-2-04	0.83	SMB-3-03	0.99	SMB-2-12	1.06
Between 2-04 and 2-06	0.83	SMB-3-04	1.06	SMB-2-13	0.95
SMB-2-05	0.92	SMB-3-09	1.03	SMB-2-14	0.88
SMB-2-06	1.02	SMB-3-05	1.03	SMB-2-15	0.92
Between 2-06 and 2-07	0.88	SMB-3-06	1.10	South of 2-15	0.85

Table 3-4  
Non-MS4 Parcels – Modeled as Treated by Treatment Plants  
(i.e, BMPs that will treat stormwater to the Water Quality Objectives)

Implementation Level	CML Analysis Region	Treatment Flowrate (cfs)	Design Storm (in/hr)	Average Basin Depth (ft)	Equalization Volume (cu-ft)	Diversion Flowrate (cfs)	Infiltration Rate (in/hr)
Non-MS4 Parcels	All	10,000	0.20	100	1,000	10,000	0.00001

### 3.3.8. Regional/Centralized Design Parameters and Criteria

Existing BMPs that were constructed after 2003; and, planned and proposed regional/centralized BMPs are modeled in SBPAT as closely as possible to their actual conceptual designs. The following sections outline the regional/centralized BMPs that were modeled as well as their drainage areas, design details in SBPAT, and any relevant assumptions. The load reduction attributable to multiple regional/centralized BMPs in series is assumed to be additive unless the BMPs are not volume-capture BMPs. In those cases, the load reductions were adjusted so as to void double counting.

The RAA included 31 BMPs modeled as infiltration basins. Model inputs for the regional/centralized BMPs are summarized in **Appendix A**. Individual BMPs, as currently proposed, and associated assumptions are described in more detail by CML analysis region below. In some cases, projects which function as harvest and use systems were modeled as infiltration basins to allow for the quantification of losses. The project descriptions following the model input table provide such operational details.

# Section 4

## Watershed Control Measures

---

As part of the development of the EWMP, the Permit specifies that watershed control measures (or BMPs) shall be identified to: 1) ensure that stormwater discharges meet receiving water and effluent limits as established in the Permit, and 2) reduce overall impacts to receiving waters from stormwater and non-stormwater runoff.

BMPs are grouped into two broad categories, structural and institutional. Structural BMPs are physically-constructed control measures that alter the hydrology or water quality of stormwater or non-stormwater. Institutional BMPs are source control measures that prevent the release of flow/pollutants or transport of pollutants, but do not involve construction of physical facilities. Minimum control measures (MCMs), such as street sweeping, are a subset of institutional BMPs.

This section summarizes watershed control measures, including BMP types and existing BMPs, which reduce the current pollutant load to meet past and future compliance requirements. In addition, this section summarizes future BMPs that will be implemented to meet 2018 and 2021 Permit compliance requirements. The 2018 and 2021 BMPs were developed as a result of the RAA analysis in combination with feedback from the SMB EWMP Group. Of the proposed/future BMPs, eight were selected as example projects wherein conceptual design, feasibility, and costs were evaluated. Detailed conceptual designs of these eight highlighted projects can be found in Appendix B.

### 4.1. INSTITUTIONAL BMPS

This section summarizes existing, in-place -MCMs located within the SMB EWMP Group area along with an outline for modifying MCMs and measuring the effectiveness of customized programs.

Required future MCMs are similar to programs that were required under the previous MS4 Permit (Order No. 01-182). The previous Permit requires continuation of existing MCMs until the SMB EWMP is approved by the Regional Board. Existing implementation summaries of the Program MCM tasks identified are available in the Unified Annual Stormwater Report. A comparison between program requirements of the previous and current MS4 Permit is shown in **Table 4-1**. MCMs are grouped into six categories as shown below:

- **Public Information and Participation Program (PIPP)** - The objectives of the PIPP are to measurably increase public knowledge, change waste disposal and runoff pollution generation behavior, and involve/engage target populations in stormwater pollution mitigation.
- **Industrial/Commercial Facilities Program** - The goal of the Industrial/Commercial Facilities Program is to track, inspect, and ensure compliance at industrial and commercial facilities that are critical sources of constituents in stormwater.
- **Development Planning Program** - The Development Planning Program implements a set of requirements for development and redevelopment projects to minimize impacts from urban runoff, maximize pervious surface areas, minimize the quantity of stormwater directed to impervious surfaces, and minimize parking lot and street pollution through BMPs.

- **Development Construction Program** - Similar to the Development Planning Program, the Development Construction Program aims to control stormwater pollution from active construction sites. This program is implemented through sediment control measures, retention and recycling of construction-related materials and wastes, containment of non-stormwater runoff from washing and other activities, and erosion/slope controls.
- **Public Agency Activities Program** - The activities under the Public Agency Activities Program include sewage system maintenance and overflow/spill prevention, public yards management, streets and roads maintenance, storm drain operation and management, emergency procedures, and other essential Permittee activities.
- **Illicit Connections and Illicit Discharges Elimination Program** - The final program under the existing MCMs is the Illicit Connections (ICs) and Illicit Discharges (IDs) Elimination Program (IC/ID). The program requires Permittees to document, track, and report all cases of IC/ID and implement a response procedure and methods for public reporting.

The opportunity for customization may provide benefits by allowing the SMB EWMP Group to assess the effectiveness of their current programs and to modify their programs to better serve local conditions and objectives. If an effectiveness assessment is conducted on a specific MCM activity and it can be reasonably shown that customization of the MCM would result in equal or improved effectiveness on attitudes or knowledge, behavior or implementation, load reduction, or water quality, then a defensible recommendation for modification of that activity can be made, resulting in greater resources available for more effective activities. **Figure 4-1** shows the process for identifying and implementing MCM customization.

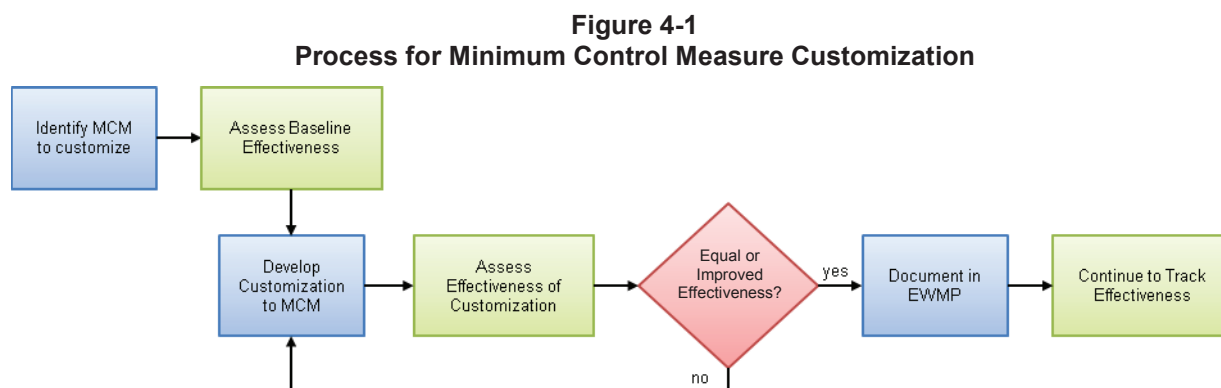

The SMB EWMP Group is interested in customizing MCM activities, with the first step being development of a framework to assess the effectiveness of each MCM currently being implemented. For each MCM that can be assessed in this manner, recommendations for customizations can be developed with reasonable assurance of impact to effectiveness.

# Watershed Control Measures

**Table 4-1  
Comparison of Stormwater Management Program MCMs**

Program Element	Activity	Order No. 01-182	Order No. R4-2012-0175
Public Information and Participation Program	Public Education Program - Advisory committee meeting (once per year)	x	
	"No Dumping" message on storm drain inlets (by 2/2/2004)	x	
	Reporting hotline for the public (e.g., 888-CLEAN-LA)	x	x
	Outreach and Education	x	
	Make reporting info available to public	x	x
	Public service announcements, advertising, and media relations	x (4.B.1.c.1)	x
	Public education materials - Proper handling	x (4.B.1.c.3)	x
	Public education materials - Activity specific	x	x
	Educational activities and countywide events	x	x
	Quarterly public outreach strategy meetings (by 5/1/2002)	x	
	Constituent-specific outreach information made available to public	x	x
	Business Assistance Program	x	
	Educate and inform corporate managers about stormwater regulations	x	
	Maintain storm water websites		x
	Provide education materials to schools (50 percent of all K-12 children every two years)	x	x
	Provide principle permittee with contact information for staff responsible for storm water public educational activities (by 4/1/2002)	x	x
	Principle permittee shall develop a strategy to measure the effectiveness of in-school education programs	x	
	Principle permittee shall develop a behavioral change assessment strategy (by 5/1/2002)	x	
	Educate and involve ethnic communities and businesses (by 2/3/2003)	x (4.B.1.c.2)	x
	Reporting hotline for the public (e.g., 888-CLEAN-LA)	x	x
Industrial/Commercial Facilities Program Industrial/Commercial Facilities Program	Track critical sources - Restaurants	x	x
	Track critical sources - Automotive service facilities	x	x
	Track critical sources - RGOs	x	x
	Track critical sources - Nurseries and nursery centers		x
	Track critical sources - USEPA Phase I facilities	x	x
	Track critical sources - Other federally-mandated facilities [40 CFR 122.26(d)(2)(iv)(C)]	x	x
	Track critical sources - Other commercial/industrial facilities that Permittee determines may contribute substantial constituent load to MS4		x
	Facility information - Name of facility	x	x
	Facility information - Contact information of owner/operator	name only	x
	Facility information - Address	x	x
	Facility information - NAICS code		x
	Facility information - SIC code	x	x
	Facility information - Narrative description of the activities performed and/or principal products produced	x	x
	Facility information - Status of exposure of materials to storm water		x
	Facility information - Name of receiving water		x
	Facility information - ID whether tributary to 303(d) listed water and generates constituents for which water is impaired		x
	Facility information - NPDES/general industrial permit status	x	x
	Facility information - No Exposure Certification status		x
	Update inventory of critical sources annually	x	x
	Business Assistance Program	optional	x
	Notify inventoried industrial/commercial sites on BMP requirement		once in 5 years
	Inspect critical commercial sources (restaurants, automotive service facilities, retail gasoline outlets and automotive dealerships)	twice in 5 years	twice in 5 years
	Inspect critical industrial sources (phase 1 facilities and federally-mandated facilities)	twice in 5 years <sup>1</sup>	twice in 5 years <sup>2</sup>
	Verify No Exposure Certifications of applicable facilities		x
	Verify WDID of applicable facilities	x	x
	Source Control BMPs	x	x
	Provisions for Significant Ecological Areas (SEAs) (Environmentally Sensitive Areas (ESAs))	x <sup>3</sup>	x
	Progressive enforcement of compliance with stormwater requirements	x	x
	Interagency coordination	x	

# Watershed Control Measures

**Table 4-1 (continued)**

Program Element	Activity	Order No. 01-182	Order No. R4-2012-0175
Planning and Land Development Program	Peak flow control (post-development stormwater runoff rates, velocities, and duration)	x	x <sup>4</sup>
	Hydromodification Control Plan	in lieu of countywide peak flow control	
	SUSMP (by 3/3/03)	x	
	Volumetric Treatment Control (SWQDv) BMPs	x	x
	Flow-based Treatment Control BMPs	x	x
	Require implementation of post-construction Planning Priority Projects as treatment controls to mitigate storm water pollution (by 3/10/2003)	x	x
	Require verification of maintenance provisions for BMPs	x	x
	CEQA process update to include consideration of potential stormwater quality impacts	x	
	General Plan Update to include stormwater quality and quantity management considerations and policies	x	
	Targeted Employee training of Development planning employees	x	
	Bioretention and biofiltration systems		x
	SUSMP guidance document	x	
	Annual reporting of mitigation project descriptions		x
Development Construction Program	Erosion control BMPs	x	x
	Sediment control BMPs	x	x
	Non-storm water containment on project site	x	x
	Waste containment on project site	x	x
	Require preparation of a Local SWPPP for approval of permitted sites	x	x
	Inspect construction sites on as-needed basis		x
	Inspect construction sites equal to or greater than one acre	once during wet season	once every two weeks <sup>5</sup> , monthly
	Electronic tracking system (database and/or GIS)		x
	Required documents prior to issuance of building/grading permit	L-SWPPP	ESCP/SWPPP
	Implement technical BMP standards		x
	Progressive enforcement	x	x
	Permittee staff training	x	x
	Public Agency Activities Program	Public construction activities management	x
Public facility inventory			x
Inventory of existing development for retrofitting opportunities			x
Public facility and activity management		x	x
Vehicle maintenance, material storage facilities, corporation yard management		x	x
Landscape, park, and recreational facilities management		x	x
Storm drain operation and maintenance		x	x
Streets, roads, and parking facilities maintenance		x	x
Parking Facilities Management		x	x
Emergency procedures		x	x
Alternative treatment control BMPs feasibility study		x	
Municipal employee and contractor training			x
Sewage system maintenance, overflow, and spill prevention		x	
IC/ID Elimination Program	Implementation program	x	x
	MS4 Tracking (mapping) of permitted connections and illicit connections and discharges	x	x
	Procedures for conducting source investigations for IC/IDs	x	x
	Procedures for eliminating IC/IDs	x	x
	Procedures for public reporting of ID		x
	IC/ID response plan	x	x
IC/IDs education and training for staff	x	x	

<sup>1</sup> Tier 2 facilities may be inspected less frequently if they meet certain criteria

<sup>2</sup> Subject to change based on approved EWMP strategy

<sup>3</sup> For environmentally sensitive areas and impaired waters

<sup>4</sup> Maintain pre-project runoff flow rates via hydrologic control measures

<sup>5</sup> Sites of threat to water quality or discharging to impaired water; frequency dependent on chance of rainfall

The California Stormwater Quality Association (CASQA) provides a framework for the effectiveness assessment of Stormwater Management Programs. The outcome is a hierarchy that categorizes the classification of outcome types (levels); these types allow MCMs to be placed into one or more categories for subsequent outcome assessment. The outcome levels, Level 1 through Level 6, are shown in **Figure 4-2**.

An assessment of required MCMs was conducted and resulted in no proposed modifications for the SMB EWMP Group Area. As a result, required MCMs shall be implemented without modifications; however, the SMB EWMP Group may consider modifications in the future using the prescribed process.

**Figure 4-2  
General Classification of Outcome types (adapted from CASQA)**

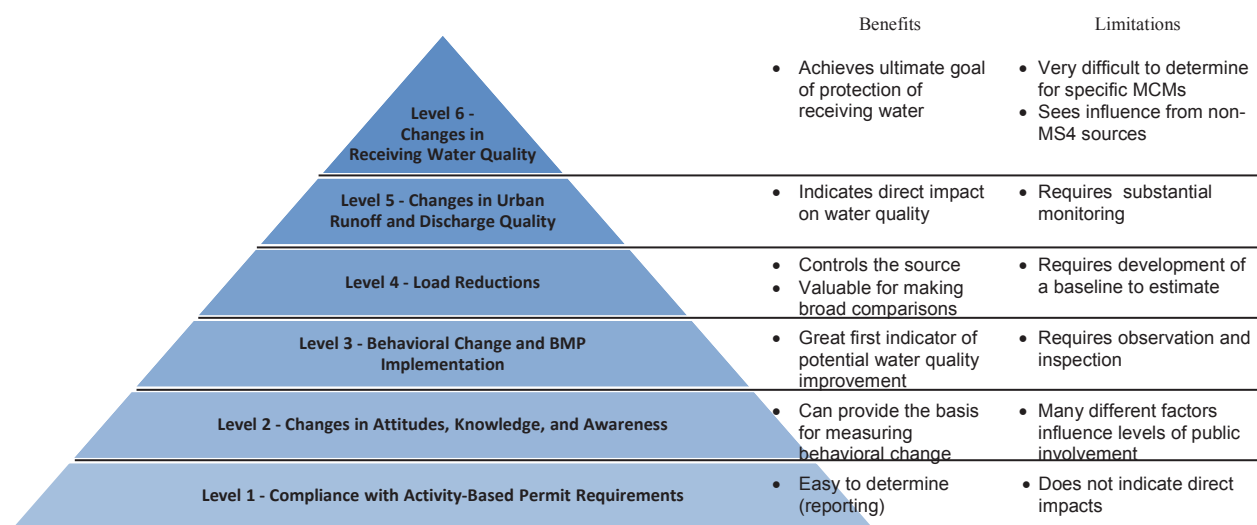

## 4.2. STRUCTURAL BMPS

Structural BMPs are anticipated to perform the majority of required pollutant reduction within the SMB EWMP Group area. To implement control measures efficiently at the watershed-scale and to support compliance tracking, structural BMP programs will be an important element of EWMP implementation. This section describes the necessary structural BMPs for EWMP implementation.

Structural BMPs are categorized as either distributed or regional. Distributed BMPs are designed to treat runoff from small drainage areas that are comprised of a single to a few parcels. Regional BMPs are designed to capture runoff from the 85<sup>th</sup> percentile, 24-hour storm from a large drainage that includes multiple parcels and various land uses. A subset of regional BMPs capable of capturing runoff are herein referred to as “Regional EWMP Projects.”

There are several existing regional and distributed structural BMPs within the SMB EWMP Group Area, as summarized in the following subsection.

## 4.2.1. Existing Regional BMPs

Existing regional BMPs were identified and characterized into BMP categories through a data request and literature review process, wherein a total of 27 regional BMPs were identified. The 27 regional BMPs are summarized in **Figure 4-2**, with locations shown on **Figure 4-3**. Three of these regional BMPs are joint projects between multiple agencies. Of the 27 existing regional projects, 23 are low-flow diversions (LFDs), two are infiltration BMPs, one is a constructed wetland, and another is a treatment facility. Additional information on existing BMPs can be found in **Appendix F**.

**Table 4-2  
Summary of Existing Regional Best Management Practices<sup>1</sup> by Permittee and Type**

Permittee	Total BMPs Reported <sup>7</sup>	Number of Existing Regional BMPs Reported by Permittee			
		Infiltration	Constructed Wetland	Treatment Facility	Low-Flow Diversion <sup>2</sup>
El Segundo	-	-	-	-	-
Los Angeles	13	2	1	1 <sup>3</sup>	9 <sup>4,5</sup>
Santa Monica	5	-	-	1 <sup>3</sup>	4 <sup>4</sup>
County <sup>6</sup>	-	-	-	-	-
LACFCD <sup>6</sup>	13	-	-	-	13 <sup>4,5</sup>

<sup>1</sup> Regional BMPs summarized in this table do not necessarily meet the Permit's criterion of capturing the 85<sup>th</sup> percentile, 24-hour storm volume to be considered a Regional EWMP Project.

<sup>2</sup> Low-Flow Diversions capture and divert 100% of dry flow.

<sup>3</sup> The Santa Monica Urban Runoff Recycling Facility (SMURRF) is a joint project between the City and City of Santa Monica.

<sup>4</sup> The Pico-Kenter LFD is a joint project between LACFCD, the City, and the City of Santa Monica.

<sup>5</sup> The Imperial Highway LFD is a joint project between LACFCD and the City.

<sup>6</sup> Data sources contain conflicting information in regard to LACFCD and County ownership of LFDs. In this table, all LFDs with this conflict have been listed with LACFCD as the responsible permittee.

<sup>7</sup> This column represents the number of BMPs for which each permittee has ownership/partial ownership. As double counting occurs when multiple permittees have ownership of a project, the numbers in each column should not be added to determine the total number of physical BMPs.

## 4.2.2. Existing Distributed BMPs

Existing distributed BMPs were characterized through a data request process that identified a total of 2,212 BMPs in the SMB EWMP Group Area. Of these distributed BMPs, 340 exist within the City of Los Angeles, and 1,872 exist within the City of Santa Monica. The BMPs identified in the City of Santa Monica reflect both city-owned and privately-owned BMPs. Existing distributed BMPs within the SMB EWMP Group area are summarized by type in **Table 4-3**. A detailed list of existing distributed BMP can be found in Appendix F. This list is a preliminary list compiled by data requests and may not include more recently constructed BMPs.

Figure 4-3  
Location of Existing Regional BMPs

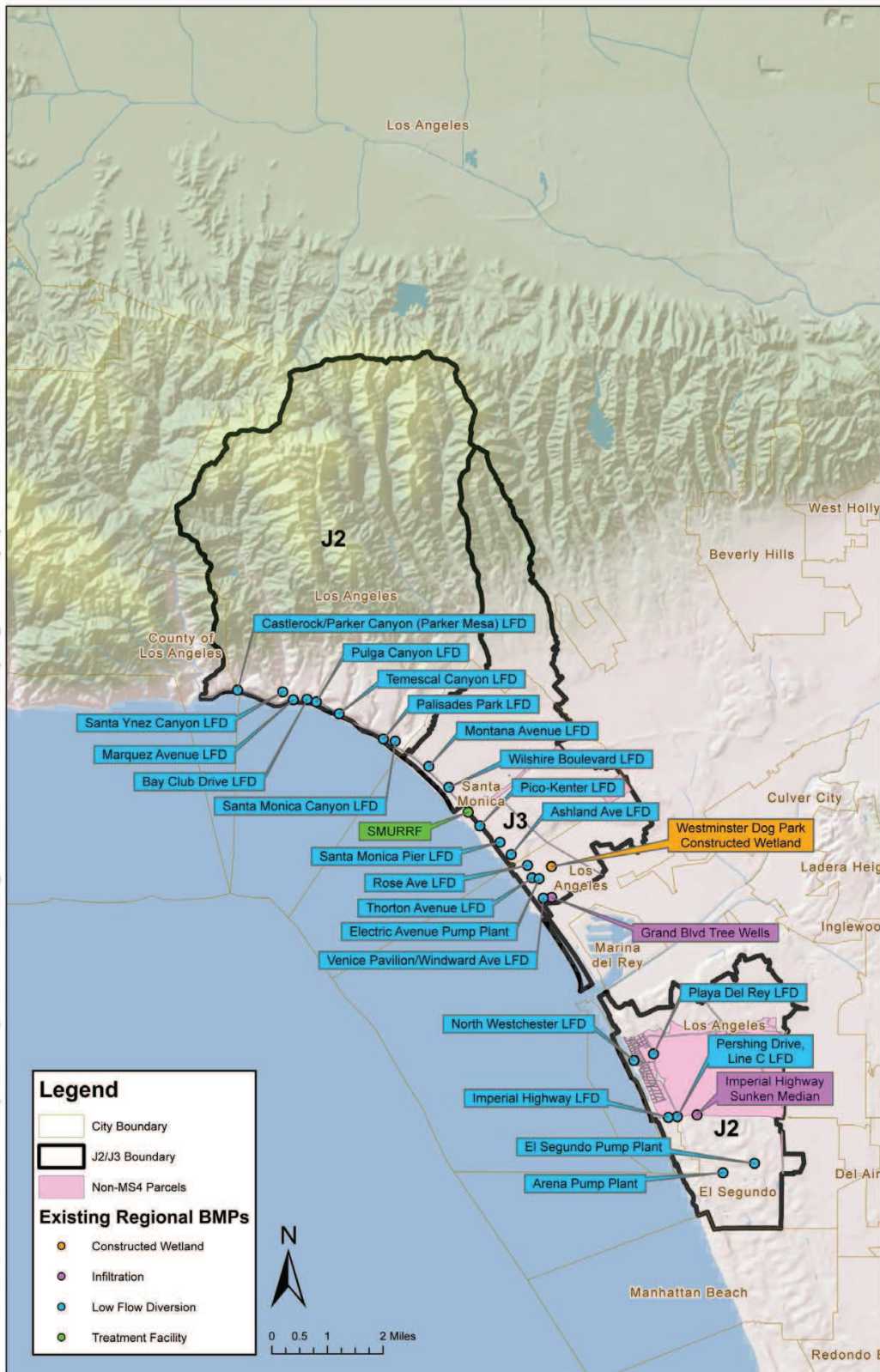

Table 4-3  
Existing Distributed Best Management Practices by Permittee and Type

Permittee <sup>2</sup>	Number of Existing Distributed BMPs by Type Reported by Permittee										
	Total BMPs Reported	Site-Scale Detention	Green Infrastructure						Flow Through	Source Control	Unknown <sup>1</sup>
			Bioretention	Biofiltration	Permeable Pavement	Bioswale	Infiltration	Rainfall Harvest			
El Segundo <sup>3</sup>	-	-	-	-	-	-	-	-	-	-	-
Los Angeles	340	14	168	-	51	11	9	44	11	31	-
Santa Monica	1872	-	1	230	89	-	1,329	1	101	-	67
County <sup>3</sup>	-	-	-	-	-	-	-	-	-	-	-
LACFCD <sup>3</sup>	-	-	-	-	-	-	-	-	-	-	-
<b>TOTAL</b>	<b>2212</b>	<b>14</b>	<b>169</b>	<b>230</b>	<b>140</b>	<b>11</b>	<b>1,338</b>	<b>45</b>	<b>112</b>	<b>31</b>	<b>67</b>

<sup>1</sup> BMPs listed as “unknown” are those for which a BMP category was not specified in the data request.

<sup>2</sup> BMPs were assigned to Permittee by geographic location in the instance that ownership information was not available.

<sup>3</sup> Distributed BMP data for El Segundo, the County, and LACFCD were not available for summary. Please see Attachment A4 and Attachment A5 to review the BMPs summarized for these Permittees in the 2011-2012 Unified Annual Stormwater Report.

**4.2.3. Planned Structural BMPs for Compliance**

The Regional Projects Initial Screening Technical Memorandum (MWH Team, 2014) documents the methods used for identifying how the parcels within the SMB EWMP Group Area were narrowed to 36 high potential regional project sites (see **Figure 4-5**). The SMB EWMP will also include multi-benefit regional projects that retain the stormwater volume from the 85th percentile, 24-hour storm for the drainage areas tributary to the multi-benefit regional projects. Eight highlighted regional EWMP project sites were selected for conceptual design – four from the City of Los Angeles, two from the City of Santa Monica and two from El Segundo. Through a screening process and coordination with the SMB EWMP Group, project sites were selected for conceptual design, cost estimation, and inclusion in the EWMP plan. The conceptual designs include preliminary sizing, BMP type, configuration, environmental constraints, construction feasibility review, preliminary cost, and schedules.

**Process for Identifying and Selecting Multi-Benefit Projects**

The EWMP process emphasizes identifying Regional EWMP projects that are individually or collectively able to capture runoff from the 85<sup>th</sup> percentile, 24-hour storm. Existing and planned BMPs and additional BMPs were considered as part of the EWMP process. This section presents the process used to identify additional potential regional EWMP projects, as illustrated schematically in **Figure 4-4**.

**Figure 4-4**  
**Process for Evaluating Regional EWMP Projects**

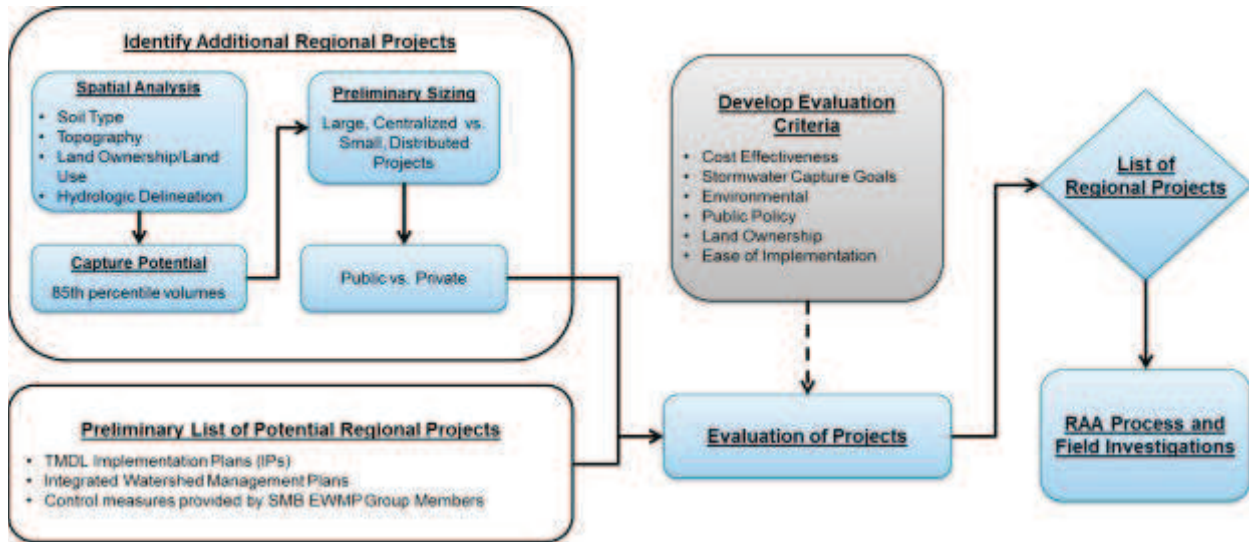

This section presents the regional projects conceptualized and modeled in the RAA analysis to meet compliance requirements. A summary of total BMP runoff retained in acre-feet (AF) by Permittee is shown **Table 4-4** for regional projects and in **Table 4-5** for distributed projects.

The LACFCD will work with the Watershed group in their efforts to address source controls; assess, develop, and pursue funding for structural BMPs, and promote the use of water reuse and infiltration. As regional project scopes are further refined, the LACFCD will determine on a case-by-case basis our contribution to the projects.

Figure 4-5  
High Potential Regional Sites

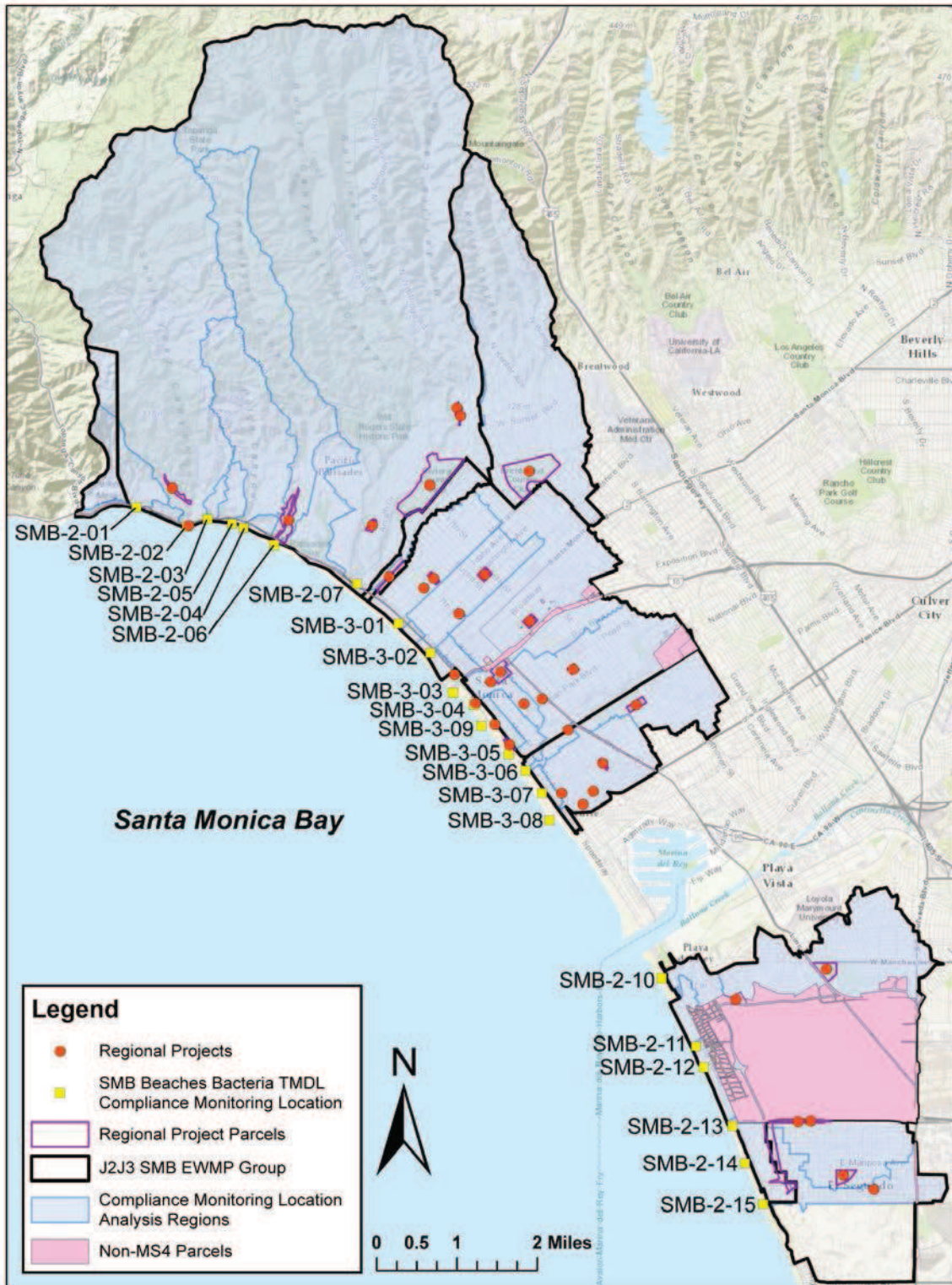

**Table 4-4**  
**Summary of Total Regional BMP Runoff Retained over Critical Year by Permittee**

Implementation Date for Compliance	Regional BMP Total Runoff Retained over Critical Year (AF)				
	County of Los Angeles	City of Los Angeles	City of Santa Monica	City of El Segundo	Total
<b>2018</b>	0.0	465.3	562.5	232.2	1260.0
<b>2021</b>	0.0	758.9	518.3	0.0	1277.2
<b>Total</b>	0.0	1224.2	1080.8	232.2	2537.2

**Table 4-5**  
**Summary of Distributed BMP Runoff Retained over Critical Year by Permittee**

Implementation Date for Compliance	Green Street BMP Capacity Required for Compliance (AF)				
	County of Los Angeles	City of Los Angeles	City of Santa Monica	City of El Segundo	Total
<b>2018</b>	4.8	283.3	184.5	0.0	472.6
<b>2021</b>	4.6	246.6	166.2	0.0	417.3
<b>Total</b>	9.4	529.9	350.7	0.0	890.0

For interim compliance (2018) the SMBBB TMDL requires a 50 percent reduction in exceedance days; this will be met by achieving 50 percent of the TLR in each CML analysis region, through a combination of non-structural, distributed green street BMPs, and existing and fast-tracked centralized/regional BMPs. These centralized/regional BMP projects are addressed by CML analysis region. It was assumed that 50 percent of the proposed distributed green streets BMPs would be implemented in all CML analysis regions between 2015 and 2018, and 50 percent would be implemented between 2018 and 2021. In CML analysis regions where no distributed green street BMPs are necessary to meet the final compliance deadlines, regional BMPs were prioritized to reduce redundant load reductions. However, in CML analysis region 2-11, a small number of distributed green street BMPs (5 percent of single family and commercial areas) were added rather than fast-tracking the large-scale regional projects, which would meet the interim and final targets if constructed alone.

**Table 4-6** lists regional and centralized BMPs required for compliance by CML analysis region. At the time of the interim compliance deadline (2018), a 22 percent load reduction is estimated watershed-wide, which is greater than the interim target load reduction of 18 percent, determined through the RAA. . At the time of the final compliance deadline (2021), a 42 percent load reduction is estimated to be achieved, which is greater than the final target load reduction of 35 percent required by the Permit. The load reduction within the CML analysis regions is primarily attributable to individual regional BMPs in each CML analysis region. Detailed descriptions of modeled BMPs for each CML analysis region can be found in Appendix A.

**Table 4-6  
Summary of Regional and Centralized BMPs Required for Compliance**

CML Analysis Region	Modeled Regional/Centralized BMP Identifier	Lead Agency <sup>1</sup>	BMP Status	Implementation Date for Compliance	
				2018 (Interim) <sup>2</sup>	2021 (Final) <sup>3</sup>
2-02	RBMP20_SantaYnez	LA	Planned		X
	RBMP23_2-2ParkingLot	LA	Proposed		X
2-06	RBMP08_Temescal	LA	Planned		X
2-07	RBMP47_RivieraLg85	LA	Planned	X	
	RMBP40b_RivieraBarranca	LA	Proposed		X
	RBMP17_Mandeville	LA	Planned		X
	RBMP43_OldOakRd	LA	Existing	X	
	RBMP48_Rustic85	LA	Proposed		X
3-01	RBMP30_GooseEggPark	SM	Proposed		X
	RBMP31_RooseveltElem	SM	Proposed	X	
	RBMP29_SanVicenteMedia	SM	Proposed		X
3-02	RBMP32_ReedPark	SM	Proposed	X	
	RBMP33_LincolnMiddleSch	SM	Proposed		X
3-03	RBMP16a_CleanBeachesP	SM	Planned	X	
3-04	RBMP44_Brentwood85	LA	Proposed		X
	RBMP51_Memorial85	SM	Proposed		X
	RBMP52_SMCivicAud85	SM	Proposed		X
	RBMP16b_CleanBeachesP	SM	Planned		X
	RBMP11_LosAmigos	SM	Proposed		X
	RBMP53_SMHSBuilt	SM	Existing	X	
3-05	RBMP37_3-5ParkingLot	SM	Proposed	X	
3-06	RMBP38_OlympicHigh	SM	Proposed		X
	RBMP13_Ozone	SM	Proposed	X	
	RBMP10_PenmarPh2*	LA	Planned	X	
	RMBP39_WillRodgersElem	SM	Proposed		X
3-07	RBMP01b_GrandBlvdIMF	LA	Existing	X	
	RBMP21b_GrandBlvdIIMF	LA	Existing	X	
	RBMP03_Westminster	LA	Existing	X	
	RBMP45_Oakwood85	LA	Proposed		X
3-09	RBMP18_CrescentBay	SM	Proposed	X	
2-11	RBMP19_WestchesterPark	LA	Planned		X
	RBMP09_WestchesterLAX	LA	Planned		X
2-13	RBMP02_ImperialHwy	ES	Existing	X	
	RBMP42_ImperialStrip	ES	Planned	X	
	RBMP50_Recreation85	ES	Proposed	X	
2-15	RBMP49_PumpStationB85	ES	Proposed	X	

<sup>1</sup> LA = Los Angeles, SM = Santa Monica, ES = El Segundo

<sup>2</sup> Load reduction credit applied/project implemented within RAA model to meet 2018 interim compliance deadline.

<sup>3</sup> Load reduction credit applied/project implemented within RAA model to meet 2021 interim compliance deadline.

It is noted that if at any time specific distributed green streets or regional/centralized BMPs are found to be infeasible for implementation, then alternative BMPs or operational changes will be planned within the same CML analysis region and within the same timeline, so as to meet an equivalent CML analysis region pollutant load reduction.

Compliance with the Debris TMDL will be met through a phased retrofit of all catch basins, -at strategic locations within the storm drain line, or combination of these two. throughout the SMB EWMP Group area to meet each interim compliance deadline (20% load reduction per year between 2016 and 2019) as well as the final compliance deadline (100% load reduction) in 2020. Consistent with the City’s Trash Monitoring and Reporting Plan (City of Los Angeles Department of Public Works, 2012), *“vertical insert[s] with 5-mm openings and flow activated opening screen covers are the best suited for implementation within the City to achieve compliance with Trash TMDLs”*. No additional BMPs were identified to meet the debris TMDL.

Existing (constructed after 2003), planned, and proposed regional/centralized BMPs were modeled to evaluate reasonable assurance in meeting compliance requirements. Project descriptions for the regional/centralized BMPs that were modeled as well as their drainage areas, design details, and any relevant assumptions are summarize below by CML analysis region. The pollutant load reduction attributable to multiple regional/centralized BMPs in series is assumed to be additive unless the BMPs are not volume-capture BMPs. In those cases, the pollutant load reductions were adjusted so as to avoid double counting. **Table 4-7** below summarizes the planned/proposed regional projects and estimated green street area by agency.

**Table 4-7  
Summary of Planned/Proposed Regional Projects and Green Street Area by Agency**

Agency	Number of Proposed/Planned Regional Projects	Proposed Green Street Area (square feet)
Los Angeles	16	4,412,791
Santa Monica	16	1,995,665
El Segundo	4	0.354087
Unincorporated Los Angeles County	0	78,657

#### 4.2.4. Regional Projects

Through an extensive screening process and coordination with the SMB EWMP Group, eight proposed regional EWMP projects were selected for conceptual design. These eight regional projects will retain, infiltrate and beneficially use stormwater runoff for the drainage area tributary to the project.

The location and BMP type of the eight proposed regional EWMP projects are summarized in **Table 4-8** and shown on **Figure 4-6**. The eight proposed project sites, selected for conceptual design were reviewed per California Environmental Quality Act (CEQA) guidelines to better understand potential environmental factors and impacts to the project sites and surrounding community. The review of CEQA

environmental factors is included in the field investigation and environmental checklist provided as **Appendix C**.

As part of the preliminary field effort, a geotechnical evaluation was completed to test the feasibility of proposed infiltration facilities. Four of the proposed sites were not included in the geotechnical evaluation due to the nature of their projects or if sufficient geotechnical information already existed for a site.

The geotechnical evaluation included review of geological information and completion of a soil penetration test. One soil boring was advanced via Cone Penetrometer Test (CPT) sounding location at each of four proposed infiltration project sites with little geotechnical data, these include Brentwood Country Club, Rustic Canyon recreation Center, Santa Monica Civic Center and Auditorium, and Recreation Park. The CPT sounding is a soil investigation method which measures the soil behavior utilizing density and friction analysis to determine the subsurface soil type. Based on preliminary geotechnical evaluation for a conceptual design of BMPs, an infiltrate facility may be feasible at the four proposed sites and further required infiltration testing is recommended to evaluate the best fit design at each location. The Geotechnical Evaluation Summary report is included as **Appendix D**. At each site, project a full geotechnical analysis should be conducted within the preliminary design phase.

**Table 4-8  
Summary Proposed of Regional EWMP Projects**

<b>Regional EWMP Project</b>	<b>BMP Type</b>	<b>Jurisdiction</b>	<b>Address / Location</b>
Brentwood Country Club	Storage, Infiltration, and Use <sup>1</sup>	City of Los Angeles	590 S Burlingame Ave, Los Angeles, CA 90049
Oakwood Recreation Center	Storage, Infiltration, and Use <sup>1</sup>	City of Los Angeles	767 California Ave, Venice, CA 90291
Riviera Country Club	Storage, Infiltration, and Use <sup>1</sup>	City of Los Angeles	1250 Capri Dr., Pacific Palisades, CA 90272
Rustic Canyon Recreation Center	Subsurface Infiltration	City of Los Angeles	601 Latimer Rd., Santa Monica, CA 90402
Line B Pump Station	Surface Infiltration	City of El Segundo	201-223 Center St., El Segundo, CA 90245
Recreation Park	Subsurface Infiltration	City of El Segundo	401 Sheldon St., El Segundo, CA 90245
Memorial Park	Storage, Infiltration, and Use <sup>1</sup>	City of Santa Monica	1401 Olympic Blvd., Santa Monica, CA 90404
Santa Monica Civic Auditorium and Courthouse	Subsurface Infiltration	City of Santa Monica	1855 Main St, Santa Monica, CA 90401

<sup>1</sup> This project is modeled as an infiltration basin with the outflow rate equal to the assumed use rate. This does not affect the load reduction achieved.

### ***Project Design Criteria***

A conceptual level design was developed for each of the example regional EWMP projects that include the selection of BMP type, preliminary sizing, configuration, and diversion pipeline alignment. Based on discussions with the SMB EWMP Group and industry standards, the criteria and assumptions developed provided the basis for the conceptual designs. During the final design process and implementation phase of the projects, these assumptions should be reevaluated.

Figure 4-6  
Eight Proposed Regional EWMP Projects



Per Los Angeles' MS4 Permit requirements, all projects were sized to retain and infiltrate the 85<sup>th</sup>-percentile, 24-hour storm event for the drainage area tributary to the project (Regional Board, 2012). Where feasible, BMPs were configured within the site's open areas to avoid removal of trees and existing facilities. Based on discussions with the SMB EWMP Group, the following BMP types were selected:

### Surface Infiltration

- Line B Pump Station

The surface infiltration facility (Line B Pump Station) is an existing retention basin that will be converted by removing the concrete lining at the bottom of the basin to allow infiltration. Based on discussions with and recommendations from the Greater Los Angeles County Vector Control District, a 96-hour drawdown time was selected for vector control. To eliminate this constraint, a floating cover is recommended to allow the use of the full depth available.

### Subsurface Infiltration

- Santa Monica Civic Auditorium and Courthouse
- Recreation Park
- Rustic Canyon Recreation Center

Subsurface infiltration facilities were sized to infiltrate the 85<sup>th</sup>-percentile, 24-hour storm volume. Storage facilities were sized to store the 85<sup>th</sup>-percentile, 24-hour storm volume. For the purposes of cost estimating, 60-inch perforated aluminized steel type II corrugated metal pipe (CMP) was selected as the system for subsurface infiltration BMPs and storage BMPs. Subsurface infiltration CMP systems were to use backfill with 40% porosity that contributes to the total BMP volume.

### Storage and Irrigation Use

- Brentwood Country Club
- Oakwood Recreation Center
- Riviera Country Club
- Memorial Park

Storage and irrigation use facilities were designed using diversion pipelines to pull from nearby, upstream existing storm drains to deliver the 85<sup>th</sup>-percentile, 24-hour storm volume to the site by gravity. For the purposes of cost estimating, diversion pipelines were assumed to be constructed of reinforced concrete pipe (RCP). The preliminary alignments of diversion pipelines were selected to utilize streets and avoid crossing major obstacles (e.g. open channels, railways, highways). A diversion structure would be constructed at the point of diversion to deliver the 85<sup>th</sup>-percentile, 24-hour storm volume to the site and allow higher flows to bypass into the existing storm drain infrastructure. For the conceptual cost estimate, pretreatment is based on CDS Hydrodynamic Separation systems (Contech, 2015).

## ***Project Components***

The regional EWMP projects consist of surface infiltration basins, subsurface infiltration systems, and storage facilities. Each of the projects will include a diversion pipe to deliver water to the site from existing storm drains. Additionally, each site will include educational components and low impact development (LID) components to provide multi-benefit features to the projects. Major components of the conceptual projects are discussed below.

## Surface Infiltration Basins

Surface infiltration basins will consist of retention basins designed to allow for infiltration of stormwater into the subsurface. The major construction components of surface infiltration basins include excavation, earthwork, inlets/outlets, and energy dissipation (e.g., riprap). Surface infiltration basins are sized to provide a 96-hour drawdown time, following vector control recommendations, based on the underlying soils potential to infiltrate. Drawdown time governs the maximum depth of the basin and, consequently, the footprint of the basin. Drawdown time can be increased if additional vector control options are considered. An example schematic of an infiltration basin is shown in **Figure 4-7** (LACDPW, 2009).

**Figure 4-7**  
**Conceptual Infiltration Basin Schematic**  
**(LACDPW, 2009)**

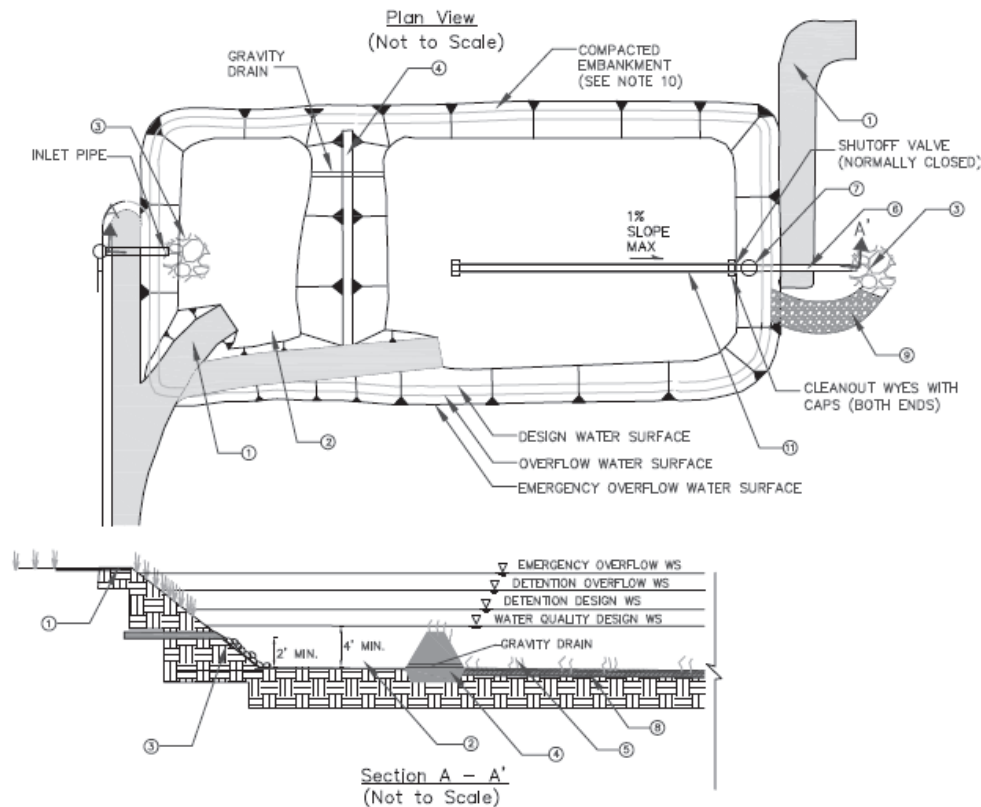

**NOTES:**

- ① MAINTENANCE RAMP SHOULD BE PAVED. SLOPE SHOULD NOT EXCEED 12%. MAINTENANCE RAMP SHOULD PROVIDE ACCESS TO BOTH THE FIRST CELL AND MAIN BASIN.
- ② UPSTREAM PRETREATMENT SHALL BE PROVIDED. SEDIMENT FOREBAY WITH VOLUME EQUAL TO 25% OF TOTAL INFILTRATION BASIN VOLUME MAY BE USED IN LIEU OF UPSTREAM PRETREATMENT. DEPTH SHALL BE 4' MIN TO 8' MAX PLUS AN ADDITIONAL 1 FOOT MIN SEDIMENT STORAGE DEPTH.
- ③ RIP RAP APRON OR OTHER ENERGY DISSIPATION.
- ④ EXTEND EARTHEN BERM ACROSS ENTIRE WIDTH OF THE INFILTRATION BASIN.
- ⑤ INFILTRATION BASIN BOTTOM AND SIDE SLOPES SHALL BE PLANTED WITH DROUGHT TOLERANT VEGETATION. DEEP ROOTED VEGETATION PREFERRED FOR BASIN BOTTOM. NO TOPSOIL SHALL BE ADDED TO INFILTRATION BASIN BED.
- ⑥ SIZE OUTLET PIPE TO PASS CAPITAL DESIGN PEAK FLOW FOR ON-LINE INFILTRATION BASINS AND WATER QUALITY PEAK FLOW FOR OFF-LINE INFILTRATION BASINS.
- ⑦ WATER QUALITY OUTLET STRUCTURE. SEE FIGURE 7-2 AND FIGURE 7-3 FOR DETAILS.
- ⑧ OVER EXCAVATE BASIN BOTTOM 1 FOOT. RE-PLACE EXCAVATED MATERIAL UNIFORMLY WITHOUT COMPACTION. AMENDING EXCAVATED MATERIAL WITH 2" - 4" OF COARSE SAND IS RECOMMENDED FOR SOILS WITH BORDER LINE INFILTRATION CAPACITY.
- ⑨ INSTALL EMERGENCY OVERFLOW SPILLWAY AS NEEDED. SEE FIGURE 2-4 FOR DETAILS
- ⑩ EMBANKMENT SIDE SLOPES SHALL BE NO STEEPER THAN 3H:1V BOTH OUTSIDE AND INSIDE.
- ⑪ INSTALL OPTIONAL 6" MINIMUM DIAMETER PERFORATED PIPE UNDERDRAIN. INSTALL AT 0.5% MINIMUM SLOPE.

Figure 6-1  
INFILTRATION BASIN

## Subsurface Infiltration Systems

Subsurface infiltration basins consist of underground storage systems designed to infiltrate stormwater into subgrade soils. Subsurface infiltration basins require structures to be placed underneath the site and backfilled to the existing site grade. Such structures are available in a variety of sizes and material types, including plastic, concrete, and metal. For the purposes of cost estimating, 60-inch CMP was assumed as the subsurface infiltration structure material type. Based on discussions with the manufacturer, the subsurface infiltration basin can be configured in a variety of shapes to match site requirements. A diversion pipe would convey stormwater to CMP headers for distribution through the subsurface infiltration basin. Access risers will be provided for operations and maintenance. Design considerations include vector control, such as sealed lids to restrict insect access. An example concept of subsurface infiltration using CMP is depicted in **Figure 4-8** (Contech, 2015).

**Figure 4-8**  
**Conceptual Subsurface Infiltration System Using CMP**  
(modified from Contech, 2015)

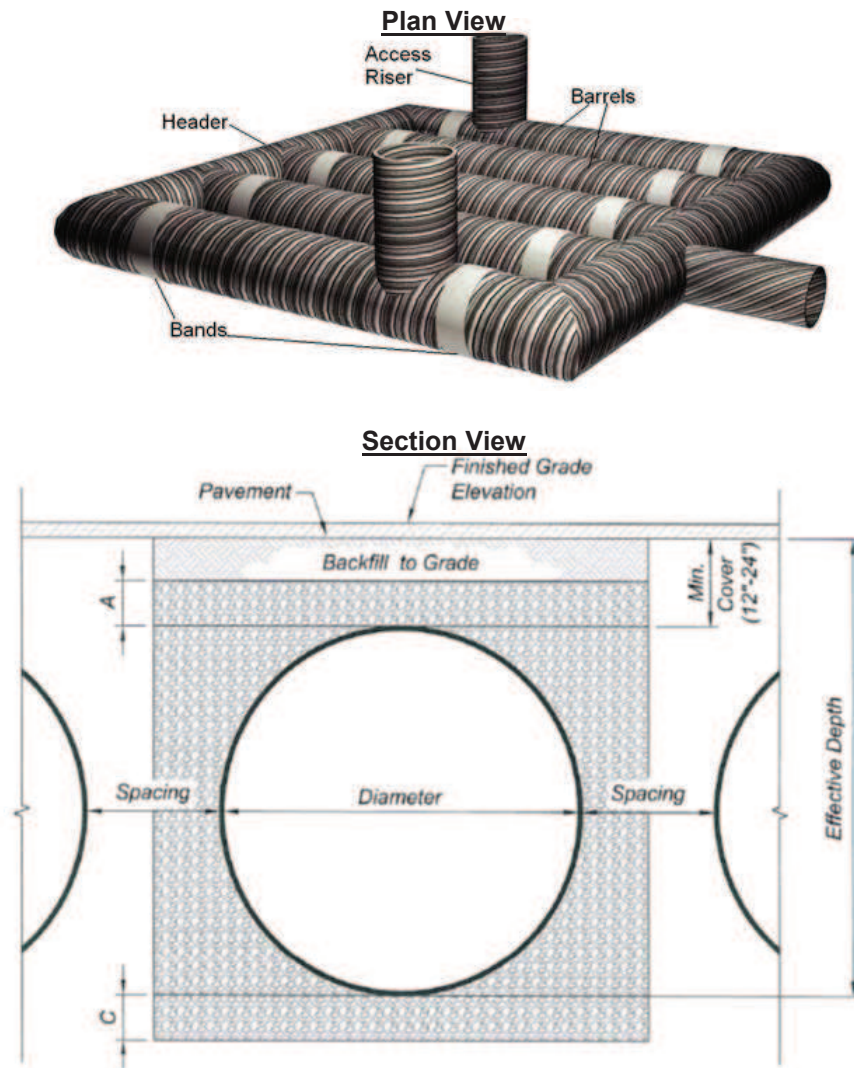

### Storage and Irrigation Use Facilities

Similar to subsurface infiltration systems, subsurface stormwater storage facilities are consist of underground storage systems designed to detain stormwater below the existing site grade. Subsurface storage facilities require structures to be placed underneath the site and backfilled to the existing site grade. Such structures are available in a variety of sizes and material types, including plastic, concrete, and metal. For the purposes of cost estimating, 60-inch CMP was assumed as the subsurface storage structure material type. Based on discussions with the manufacturer, subsurface storage facilities can be configured in a variety of shapes to match site requirements. A diversion pipe would convey stormwater to CMP headers for distribution throughout the storage system. Access risers will be provided for operations and maintenance. A photograph of a CMP detention system being installed at a real site is shown on **Figure 4-9** (Contech, 2015). In addition to CMP storage, a chlorine contact tank and pump station is required to disinfect and deliver treated stormwater for irrigation use.

**Figure 4-9**  
**Photograph Storage/Detention System Using CMP**  
**(Contech, 2015)**



### Diversion Structure and Piping

To deliver water to the sites, diversion structures and piping will be constructed to connect existing storm drains to the BMP. Diversion structures are designed to convey the required water quality flow to the BMP and allow excess flows to bypass through the existing storm drain. Diversion structures may be constructed in a manhole or subsurface tank and include hydraulic controls (e.g., weirs) and/or mechanical controls (e.g., valves and rubber dams). For the purposes of cost estimating, it was assumed that diversion pipelines would be constructed of RCP. Adequate hydraulic head is required to deliver water to the BMP by gravity. A hydraulic analysis must be conducted to confirm hydraulic limitations of

the diversion structure and pipeline during the full-scale design phase. An example diversion structure is shown in **Figure 4-10** (LACDPW, 2009).

**Figure 4-10**  
**Conceptual Diversion Structure Drawing**

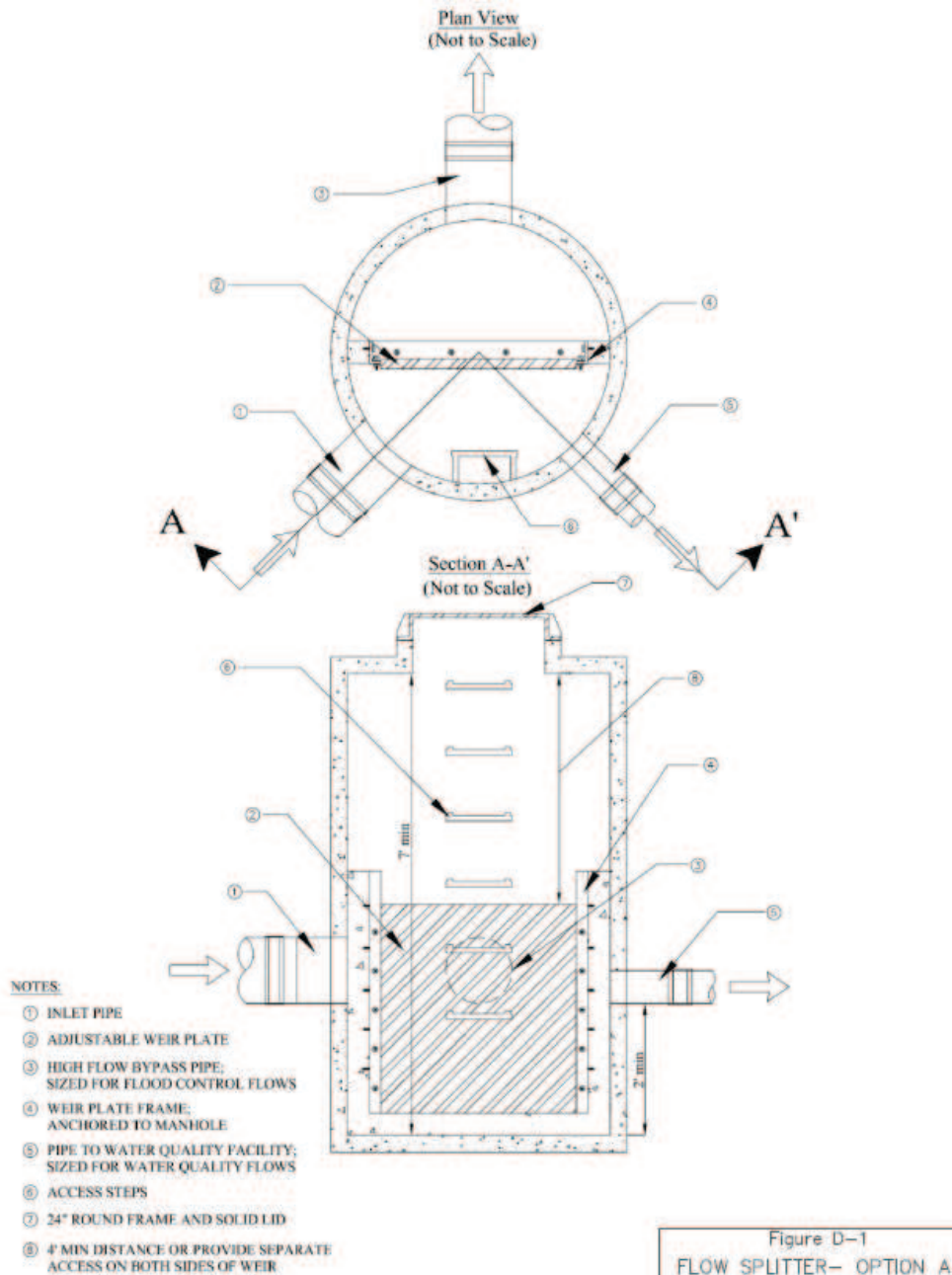

### Pretreatment Facilities

Pretreatment of storm water runoff is an important component of both surface and subsurface infiltration facilities and provides benefits for storage facilities. Removal of sediment, trash, and debris will greatly reduce maintenance required for the infiltration facilities and increase the useful life of the BMP. Pretreatment can also reduce the maintenance associated with storage facilities. There are a variety of technologies available for treating runoff, including hydrodynamic separators, mechanical filters, and biofilters. For the purposes of these conceptual designs, a hydrodynamic separator (swirl chamber type

system) is chosen to remove sediment and debris in stormwater prior to being conveyed to each regional EWMP project. As depicted in **Figure 4-11**, continuous deflection separators (CDS) units are pre-cast units placed downstream of drain inlets to capture sediment and debris, and can be manufactured in a variety of configurations. These underground units create a vortex of water that allows water to escape through the screen, while contaminants are deflected into the sump, and later removed. The CDS units are intended to screen litter, fine sand, and larger particles that can have other pollutants adsorbed to them. They can act as a first screen influence for trash and debris, vegetative material, oil and grease, and heavy metals. Multiple units in parallel may be required for high flows.

**Figure 4-11**  
**Example CDS Pretreatment Unit**  
**(Contech, 2015)**

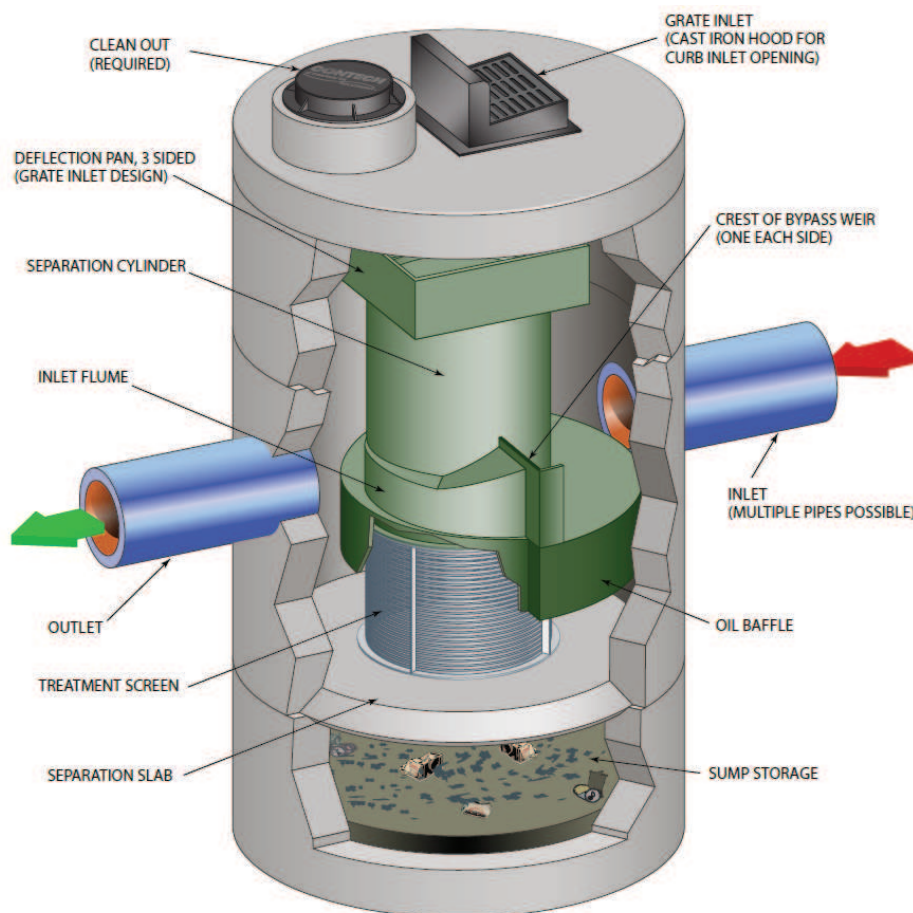

### ***Project Sizing and Configuration***

Calculations were performed to determine the approximate size required to capture the 85<sup>th</sup>-percentile, 24-hour storm volume for each project site. Next, layouts were developed to site the BMP footprint and diversion pipeline on an aerial photograph for each project site.

The 85<sup>th</sup>-percentile, 24-hour storm volume was determined using the County of Los Angeles Modified Rational Method,

$$V = \frac{A \times P \times C_d}{12},$$

where  $V$  is the 85<sup>th</sup>-percentile, 24-hour storm volume in acre-feet,

$A$  is the drainage area in acres

$P$  is the precipitation depth corresponding to the 85<sup>th</sup>-percentile, 24-hour storm in inches per hour

$C_d$  is the developed runoff coefficient, as follows:

$$C_d = 0.9 \times Imp + C_u \times (1 - Imp),$$

where  $C_d$  is the developed runoff coefficient

$Imp$  is the impervious percentage of the drainage area

$C_u$  is the undeveloped runoff coefficient (assumed to be a constant 0.1)

Infiltration rates for each site were determined using GIS soils data and soil infiltration curves from the County of Los Angeles, Department of Public Works Hydrology Manual (LACDPW, 2006 and County of Los Angeles, 2014). Additional data will be gathered during geotechnical sampling of the project sites. **Table 4-9** summarizes the Rational Method inputs for each site. **Table 4-10** presents the capture volumes and infiltration rates used to size the BMPs for each project site.

Sizing of subsurface infiltration basins and subsurface storage facilities was calculated using the Contech CMP Detention System – Rectangular DYODSTM tool (Contech, 2015). The sizing of subsurface infiltration basins and storage facilities is shown in **Table 4-11**. Estimated excavation and backfill volumes were developed for each project site and are summarized in **Table 4-12**.

**Table 4-9  
Rational Method Inputs**

Regional EWMP Project	Drainage Area (acres)	85 <sup>th</sup> -Percentile, 24-hour Storm Rainfall Depth <sup>1</sup> (inches)	Percent Impervious Area <sup>2</sup> (%)	Developed Runoff Coefficient <sup>3</sup> (-)	85 <sup>th</sup> -Percentile, 24-hour Storm Volume (acre-feet)
Brentwood Country Club	173.6	1.07	21.6	0.27	4.2
Oakwood Recreation Center	14.5	1.07	63.6	0.61	0.8
Riviera Country Club	4590.6	1.03	14.1	0.21	3.1
Rustic Canyon Recreation Center	50.1	0.97	16.1	0.23	0.9
Line B Pump Station	262.2	0.93	78.3	0.73	14.8
Recreation Park	41.5	0.92	73.2	0.69	2.2 <sup>4</sup>
Memorial Park	135.9	1.06	83.6	0.77	9.2
Santa Monica Civic Auditorium and Courthouse	88.0	1.04	61.5	0.59	4.5

<sup>1</sup> From LA County Department of Public Works GIS (<http://dpw.lacounty.gov/wrd/hydrologygis/>).

<sup>2</sup> From LA County Department of Public Works as part of the WMMS package (<http://dpw.lacounty.gov/wmd/wmms/>).

<sup>3</sup> Assumes undeveloped runoff coefficient of 0.1.

<sup>4</sup> Scaled to include the storm volume generated from Recreation Park itself.

## Watershed Control Measures

**Table 4-10  
Conceptual Design Inputs**

Regional EWMP Project	Total Size (acres)	85 <sup>th</sup> -Percentile, 24-hour Storm Volume (acre-feet)	Infiltration Rate (inches per hour)	Estimated Diversion Pipe Diameter (inches) <sup>1</sup>	Estimated Diversion Pipe Length (feet)
Brentwood Country Club	129.3	4.2	n/a <sup>2</sup>	18	190
Oakwood Recreation Center	3.6	0.8	n/a <sup>2</sup>	12	750
Riviera Country Club	158.2	3.1 <sup>5</sup>	n/a <sup>2</sup>	18	1,800
Rustic Canyon Recreation Center	8.1	0.9	0.36	12	3,680
Line B Pump Station	2.2	14.8	0.72	n/a <sup>3</sup>	0 <sup>4</sup>
Recreation Park	19.7	2.2	0.72	18	1,240
Memorial Park	10.3	9.2	n/a <sup>2</sup>	30	1,830
Santa Monica Civic Auditorium and Courthouse	6.9	4.5	0.63	24	130

<sup>1</sup> Sized for peak velocity of 10 feet per second assuming peak flow rate is one-third the 85<sup>th</sup>-percentile, 24-hour storm volume over one hour.

<sup>2</sup> Not applicable for storage projects.

<sup>3</sup> No diversion pipe necessary, Line B Pump Station Project uses existing storm drain infrastructure.

<sup>4</sup> Assumes no additional piping necessary as stormwater in the drainage area is already conveyed to this location.

<sup>5</sup> This project is not designed for the 85<sup>th</sup> percentile, 24 hour storm volume due to large size.

## Watershed Control Measures

**Table 4-11  
CMP Infiltration/Storage Sizing<sup>1</sup>**

Regional EWMP Project	85th Percentile Volume (cubic feet)	Pipe Storage (cubic feet)	Backfill Storage (cubic feet)	Depth to Invert (feet)	Number of CMP Pipes	Total Length (feet)	Total Width (feet)
Brentwood Country Club	183,912	184,088	0 <sup>3</sup>	7	12	781	90
Oakwood Recreation Center	34,310	34,400	0 <sup>3</sup>	25	11	159	82
Riviera Country Club Client Revised	134,248	134,372	0 <sup>3</sup>	7	12	570	90
Rustic Canyon Recreation Center	40,401	28,323	12,272 <sup>3</sup>	7	10	144	75
Line B Pump Station	n/a <sup>5</sup>						
Recreation Park	94,376	66,121	28,807 <sup>4</sup>	7	20	168	150
Memorial Park	401,875	402,742	0 <sup>3</sup>	7	52	394	390
Santa Monica Civic Auditorium and Courthouse	196,739	137,121	59,916 <sup>4</sup>	7	28	249	210

<sup>1</sup> Developed using Contech CMP Detention System – Rectangular DYODSTM tool (Contech, 2015). Additional information on the tool is available at <http://www.conteches.com/products/stormwater-management/detention-and-infiltration/cmp-detention-and-infiltration.aspx#2004317-technical-info>.

<sup>2</sup> Depth to CMP invert assumes at minimum two feet of cover; actual depth will change due to diversion pipe slope requirements and other site-specific requirements that will be identified in subsequent design phases.

<sup>3</sup> No backfill storage for storage BMPs.

<sup>4</sup> Assumes backfill media has a porosity of 40%.

<sup>5</sup> Not applicable for Line B Pump Station.

Assumptions: (1) 60-inch CMP pipes; (2) 30-inch spacing between CMP pipes per AISI standards; and (3) two feet of clearance between site grade and top of CMP system.

**Table 4-12  
Estimated Excavation and Backfill Volumes of BMP**

Regional EWMP Project	Total Excavation (cubic yards)	Structural Backfill (cubic yards)	Backfill to Grade (cubic yards)
Brentwood Country Club <sup>1</sup>	19,417	7,421	5,178
Oakwood Recreation Center <sup>1</sup>	12,314	1,382	9,658
Riviera Country Club Client Revised <sup>1</sup>	14,171	5,415	3,779
Rustic Canyon Recreation Center <sup>1</sup>	2,980	1,136	795
Line B Pump Station <sup>2</sup>	4,343	4,343	0
Recreation Park <sup>1</sup>	6,977	2,667	1,860
Memorial Park <sup>1</sup>	42,629	16,345	11,368
Santa Monica Civic Auditorium and Courthouse <sup>1</sup>	18,355	5,548	3,864

<sup>1</sup> Developed using Contech CMP Detention System – Rectangular DYODSTM tool (Contech, 2015). Additional information on the tool is available at <http://www.conteches.com/products/stormwater-management/detention-and-infiltration/cmp-detention-and-infiltration.aspx#2004317-technical-info>.

<sup>2</sup> Assumes excavation of 21,000 square foot base at a depth of 5 feet and 8 inches for media backfill (2 inches of pea gravel, 5 feet of washed gravel, and 6 inches of sand).

### ***Conceptual Design Illustrations***

Project concepts are described and illustrated in this section. Each Regional EWMP Project site layout is shown, including conceptual locations of BMPs, diversion piping, and other project elements.

**Brentwood Country Club**

The conceptual design for the Brentwood Country Club Regional EWMP Project consists of diversion of stormwater from a city storm drain adjacent the Brentwood Line BI 0042. Stormwater is conveyed by gravity and stored in a 60-inch CMP storage system for later irrigation use. **Figure 4-12** illustrates the Brentwood Country Club project.

**Figure 4-12  
Brentwood Country Club Project Concept**



## Oakwood Recreation Center

The conceptual design for the Oakwood Recreation Center Regional EWMP Project consists of diversion of stormwater from surface street runoff or a city storm drain (the storm drains in this area need to be verified). Stormwater would be conveyed by gravity and stored in a 60-inch CMP storage system for later irrigation use. **Figure 4-13** shows the Oakwood Recreation Center project concept.

**Figure 4-13**  
**Oakwood Recreation Center Project Concept**



Riviera Country Club

The conceptual design for the Riviera Country Club Regional EWMP Project consists of diversion of stormwater from the Santa Monica Canyon Channel. Stormwater would be conveyed by gravity and stored in a 60-inch CMP storage system for later irrigation use. **Figure 4-14** illustrates the Riviera Country Club project concept.

**Figure 4-14**  
**Riviera Country Club Project Concept**

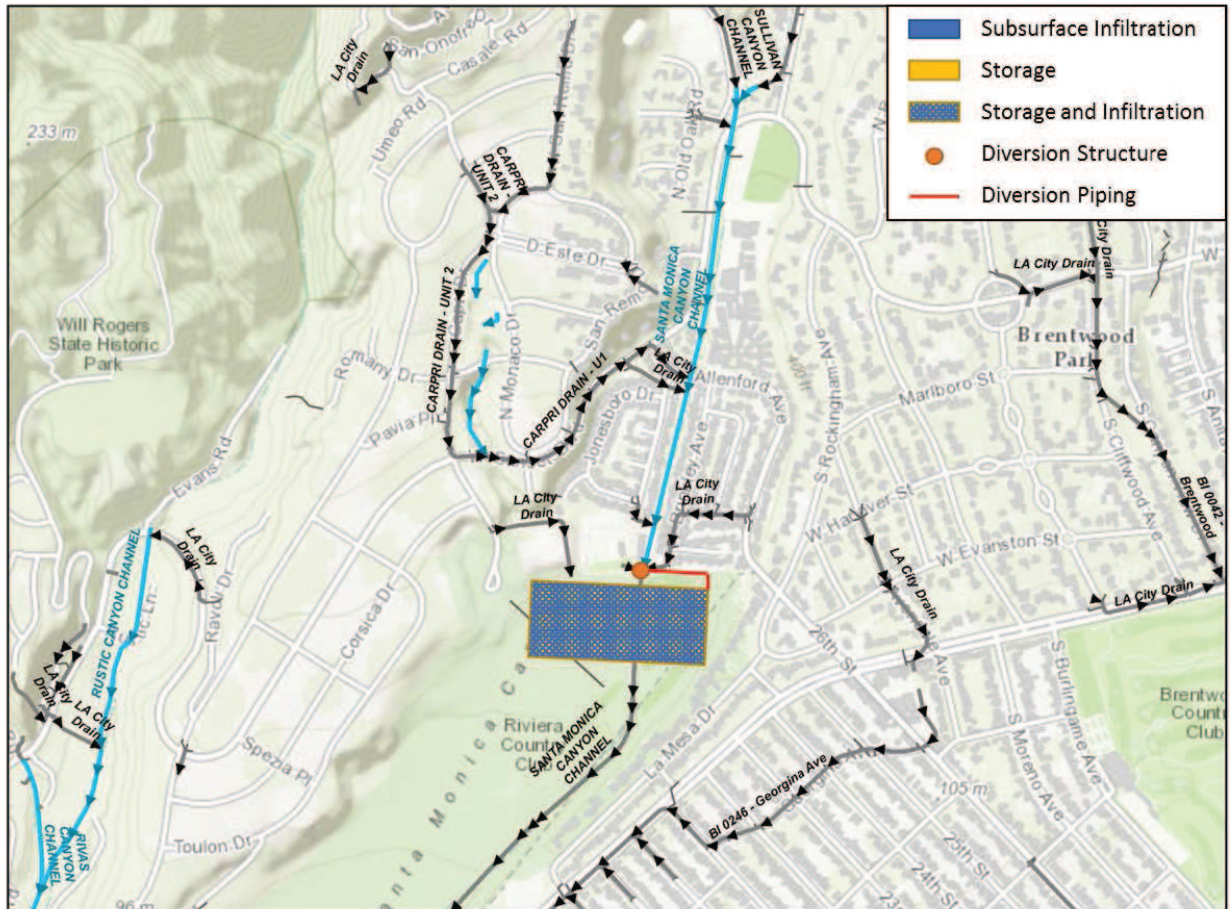

Rustic Canyon Recreation Center

The conceptual design for the Rustic Canyon Recreation Center Regional EWMP Project consists of diversion of stormwater from two city storm drains northeast of the park. The northern diversion point is chosen because of the larger drainage area contribution at this location; flow from this point drains south and east to the Santa Monica Canyon Channel. Next, flow is rerouted along Amalfi Drive and meets the second diversion point that would then divert flow to Rustic Canyon Recreation Center. Stormwater would be conveyed by gravity and infiltrated via a 60-inch CMP infiltration system. **Figure 4-15** illustrates the Rustic Canyon Recreation Center project concept.

**Figure 4-15**  
Rustic Canyon Recreation Center Project Concept

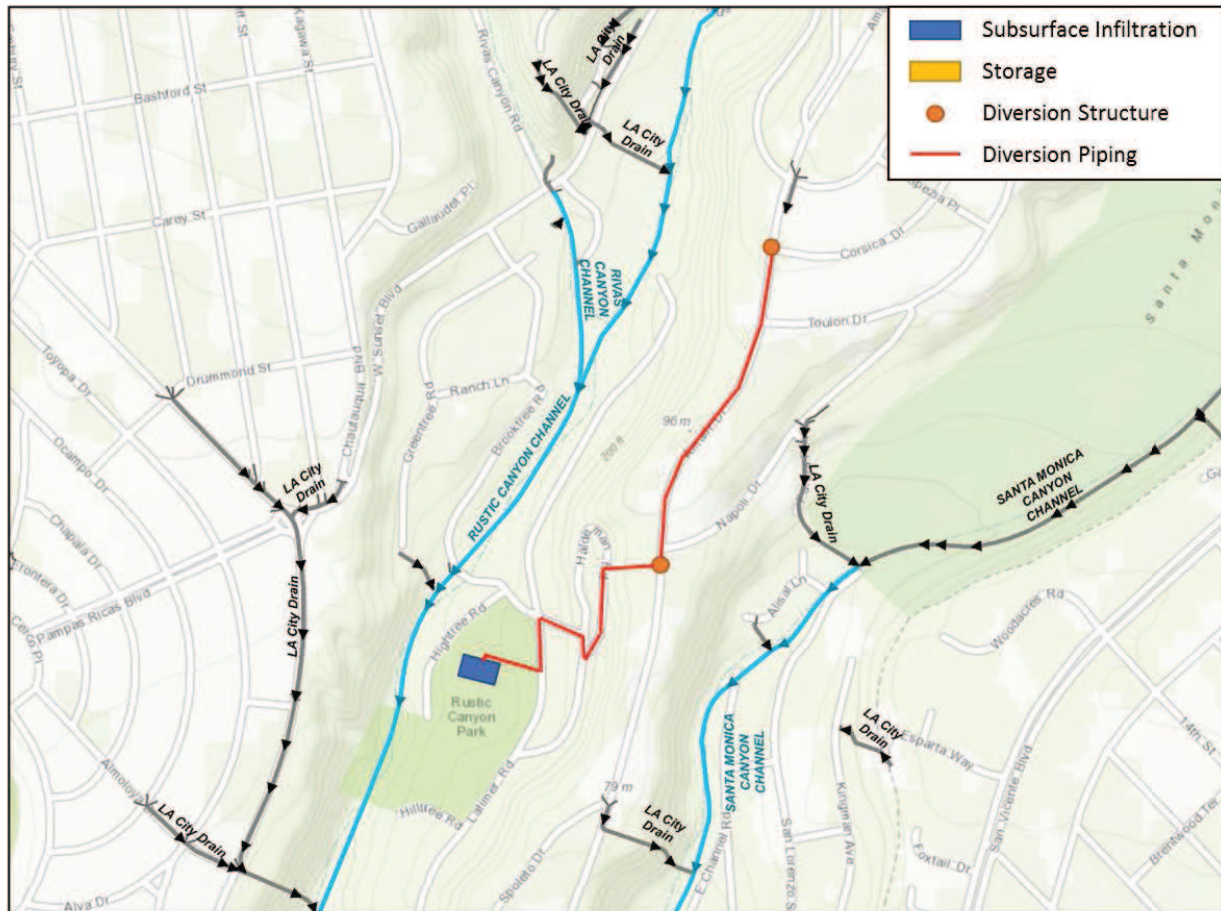

Line B Pump Station

The conceptual design for the Line B Pump Station Regional EWMP Project consists of using the existing retention basin at the site and replacing the basin invert's concrete base with a media fill optimized for infiltration. Areas east of the site currently drain to the retention basin, via Line BI 9818-U2 and others, and no additional diversions are necessary. Stormwater would be conveyed by gravity for infiltration. A floating cover would be installed to allow for the use of the full depth of the existing basin without restrictions due to vector control. Additionally, the existing pump station could be used to send stormwater to the drain along El Segundo Blvd if needed. **Figure 4-16** illustrates the Line B Pump Station project concept.

Figure 4-16  
Line B Pump Station Project Concept



## Recreation Park

The conceptual design for the Recreation Park Regional EWMP Project consists of diversion of stormwater from two city storm drains northeast of the park. Stormwater would be conveyed by gravity and infiltrated via a 60-inch CMP infiltration system. **Figure 4-17** illustrates the Recreation Park project concept.

**Figure 4-17**  
**Recreation Park Project Concept**

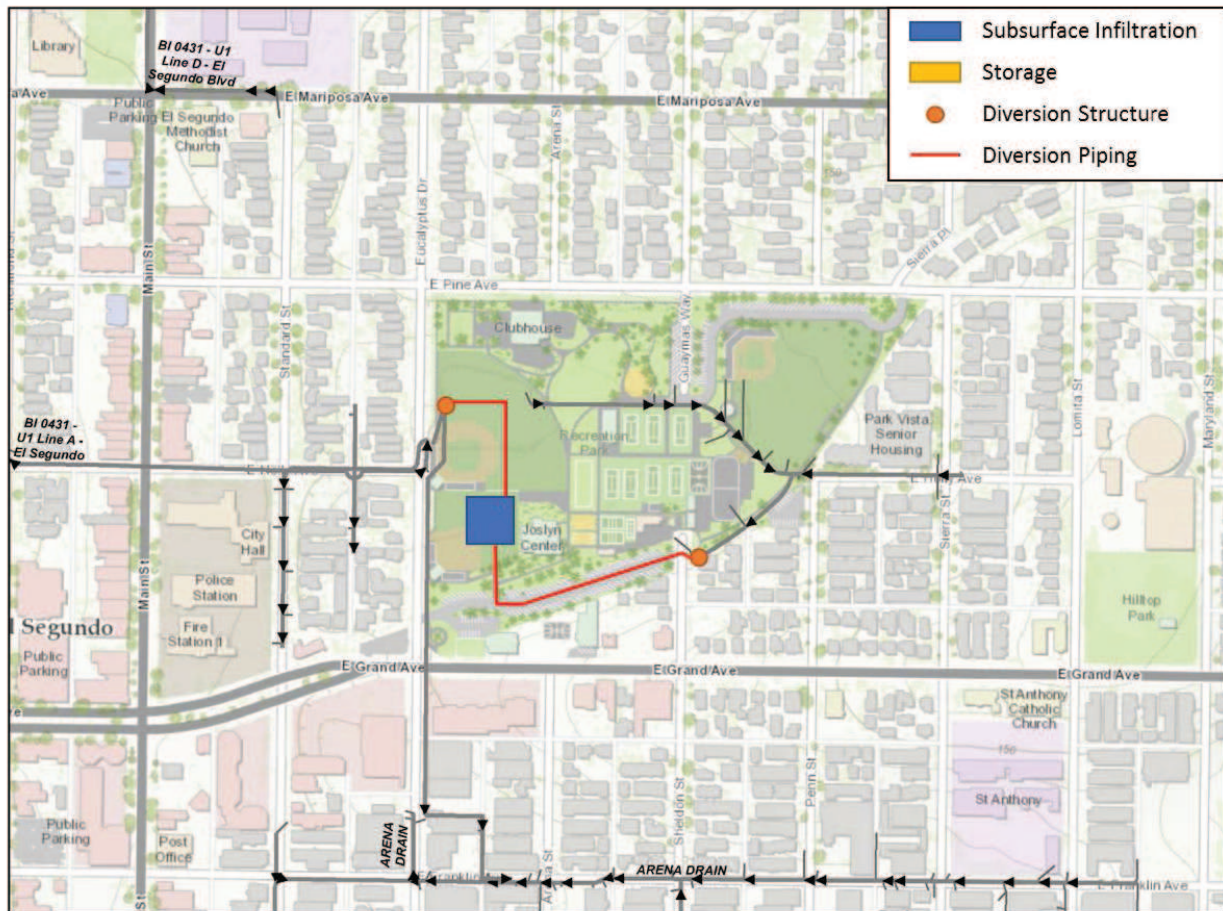

## Memorial Park

The conceptual design for the Memorial Park Regional EWMP Project consists of diversion of stormwater from BI 7403-U1 Line J and a city storm drain. Stormwater would be conveyed by gravity and stored in a 60-inch CMP storage system for later irrigation use. **Figure 4-18** illustrates the Memorial Park project concept.

**Figure 4-18**  
**Memorial Park Project Concept**



## Santa Monica Civic Auditorium and Courthouse

The conceptual design for the Recreation Park Regional EWMP Project consists of diversion of stormwater from BI 0249-U2 Line B (along Pico Blvd.). Stormwater would be conveyed by gravity and infiltrated via a 60-inch CMP infiltration system. **Figure 4-19** illustrates the Santa Monica Civic Auditorium and Courthouse project concept.

**Figure 4-19**  
**Santa Monica Civic Auditorium and Courthouse Project Concept**

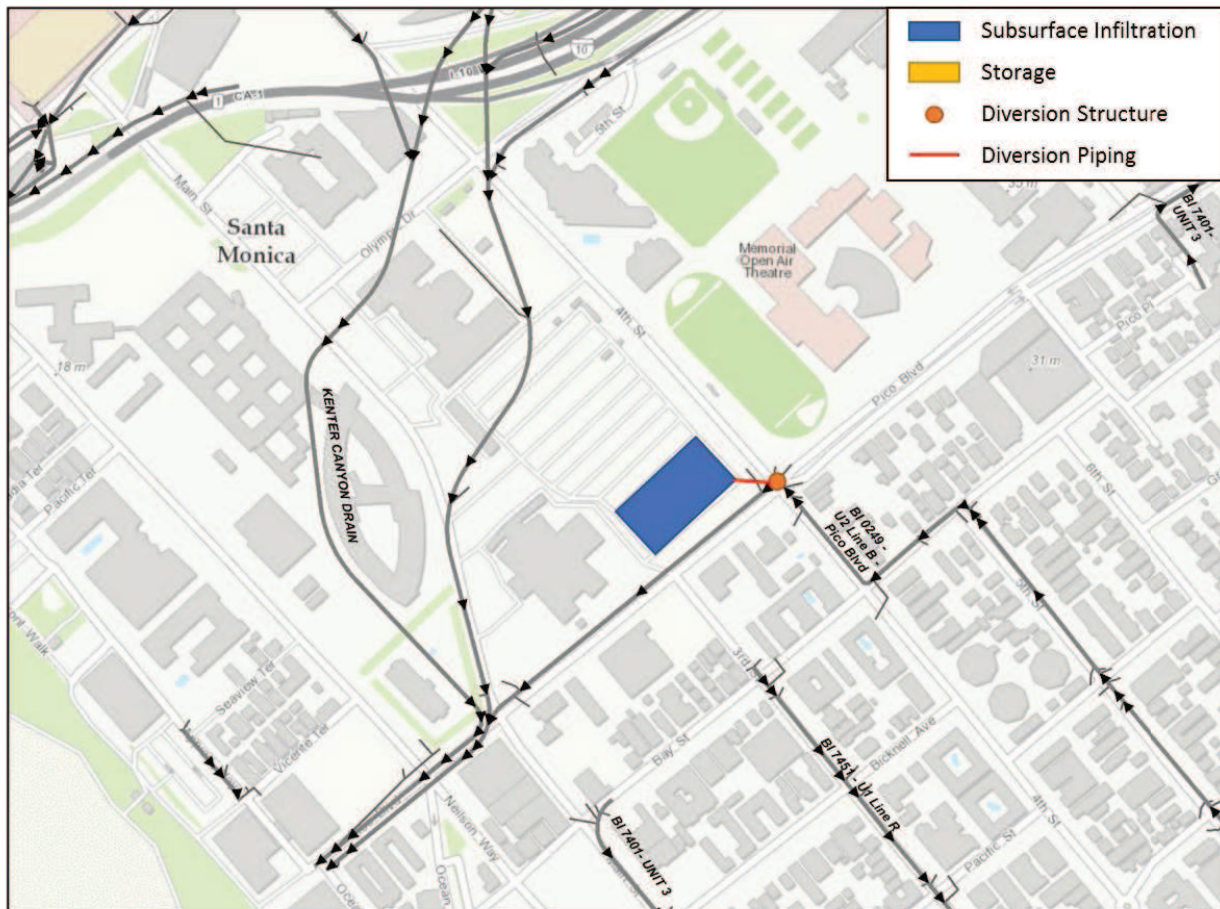

### 4.2.5. Green Streets

The right-of-way along streets may be one of the most extensive opportunities to implement BMPs on public land. In developed areas, curbs and gutters provide the primary means of conveying stormwater (and associated pollutants) directly to storm drain inlets and receiving waters. Green streets provide an opportunity to intercept this runoff prior to entering the MS4 and treat it within the extents of the public right-of-way. Green streets have been demonstrated to provide “complete streets” benefits in addition to stormwater management, including pedestrian safety and traffic calming, street tree canopy and heat island effect mitigation, increased property values, and even reduced crime rates.

As with LID, green streets tend to be distributed practices that are deployed throughout a watershed to treat runoff near the source. When compared to LID projects, key advantages of green streets, are that

they are located on land directly controlled by public entities and can intercept runoff from larger upstream drainage areas.

Green streets are typically implemented as linear bioretention/biofiltration practices installed parallel to roadways. Bioretention stormwater treatment facilities are landscaped shallow depressions that slow capture and filter stormwater runoff. These facilities function as a soil- and plant-based filtration device that removes pollutants through a variety of natural physical, biological, and chemical treatment processes. The facilities normally consist of a ponding area, mulch layer, planting soils, and plantings. As stormwater passes down through the soil, pollutants are filtered, adsorbed, and biodegraded by both soil and plants. An optional gravel layer can be added below the planting soil to provide additional storage volume for infiltration. Bioretention is typically designed without an underdrain in areas of high soil permeability – runoff treated via filtration infiltrates to the underlying soils after leaving the unit. Bioretention with an underdrain (or “biofiltration”) is a treatment control measure that can be used for areas with low permeability native soils or steep slopes, allowing for the treatment of runoff through filtration despite impermeable underlying soils. Bioretention can also be designed with a raised underdrain (or “bioinfiltration”) to function more as an infiltration / full-capture BMP. **Figure 4-20** through **Figure 4-22** show different views of an example green street project. **Figure 4-23** presents a typical green street schematic. Permeable pavement can also be implemented in tandem, or as a standalone practice, in parking lanes of roads. A typical permeable pavement schematic is shown in **Figure 4-24**.

**Figure 4-20**  
**Example Green Streets Project in Pacific Palisades – View 1**



Figure 4-21  
Example Green Streets Project in Pacific Palisades – View 2



Figure 4-22  
Section View of Bioretention with Underdrain



**Figure 4-23**  
**Typical Distributed Green Street Schematic**

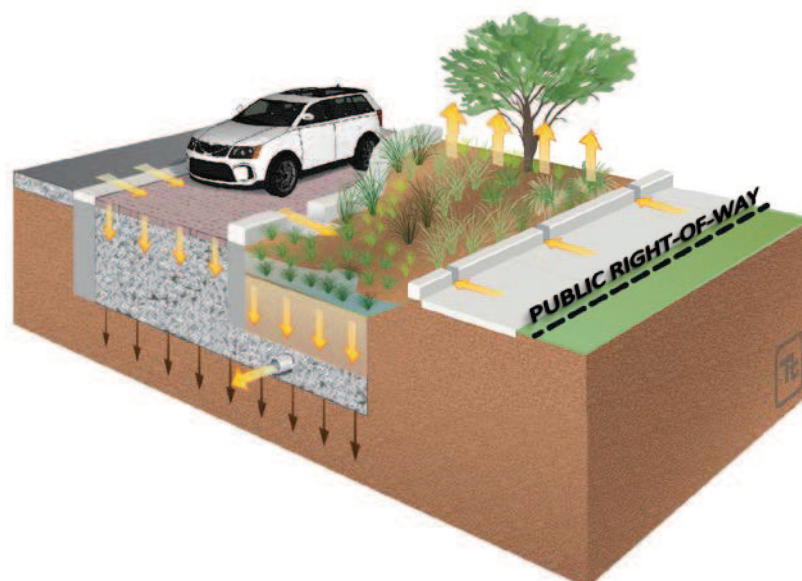

**Figure 4-24**  
**Typical Distributed Permeable Pavement Schematic with Underdrain**

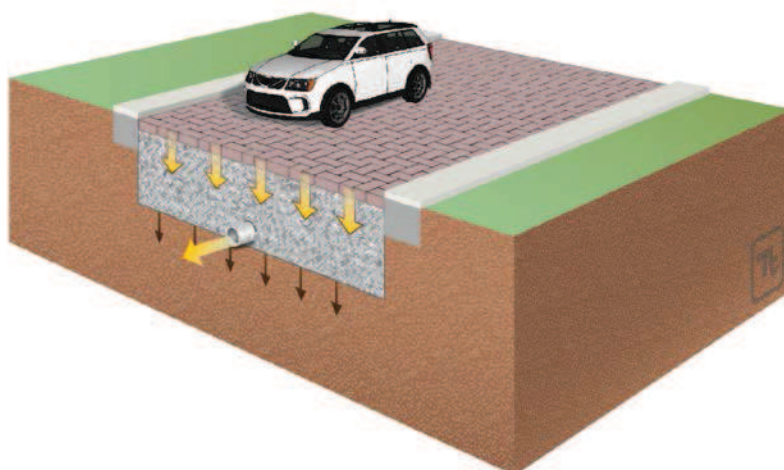

Notes: Arrows indicate water pathways.  
Images courtesy of Upper San Gabriel River Enhanced Watershed Management Program Plan.

Due to the large number of locations where green streets could be implemented, it is anticipated that a green streets program will be a key element of the compliance strategy for the EWMP. The development of a reliable, repeatable, and cost-effective program will require several considerations:

- Development and integration of standard specifications and drawings tailored to meeting EWMP objectives;
- Development of data sets necessary to make street-scale site selection decisions;
- Strategic identification and prioritization of street-scale opportunities (that can significantly reduce capital costs);
- Coordination with existing street and/or utility rehabilitation programs;

- Adaptation and/or enhancement of existing O&M practices for roadside bioretention and permeable pavement; and
- BMP tracking systems.

Although the green streets program will carry significant responsibility for achieving EWMP goals, these efforts must be balanced with other programs, especially the residential LID program and the regional BMP program. For example, downstream of places where the residential LID program is heavily implemented, or upstream of locations where large regional projects are constructed, the need for green street retrofits would be reduced.

### 4.2.6. Additional Structural BMPs

A preliminary list of planned regional projects has been developed for the EWMP based on a review of existing watershed planning documents, including TMDL Implementation Plans, Integrated Regional Water Management Plans, and other documents provided by the SMB EWMP Group. Alongside this preliminary list, additional distributed structural BMPs were considered. Detailed descriptions of structural BMP types can be found in the EWMP Work Plan. (MWH Team A, 2014).

Bioswales were also considered as an additional structural BMP. Bioswales (also known as vegetated swales) are open, shallow channels with low-lying vegetation covering the side slopes and bottom topography in order to collect and slowly convey runoff to downstream discharge points. Bioswales provide pollutant removal through settling and filtration in the vegetation (usually grasses) lining the channels, thereby allowing for stormwater volume reduction through infiltration and evapotranspiration, reduction in the flow velocity, and conveyance of stormwater runoff. The vegetation in the bioswale can vary depending on its location and design criteria outlined in this section. **Figure 4-25** shows a schematic of a typical distributed bioswale.

**Figure 4-25**  
**Typical Bioswale Schematic**

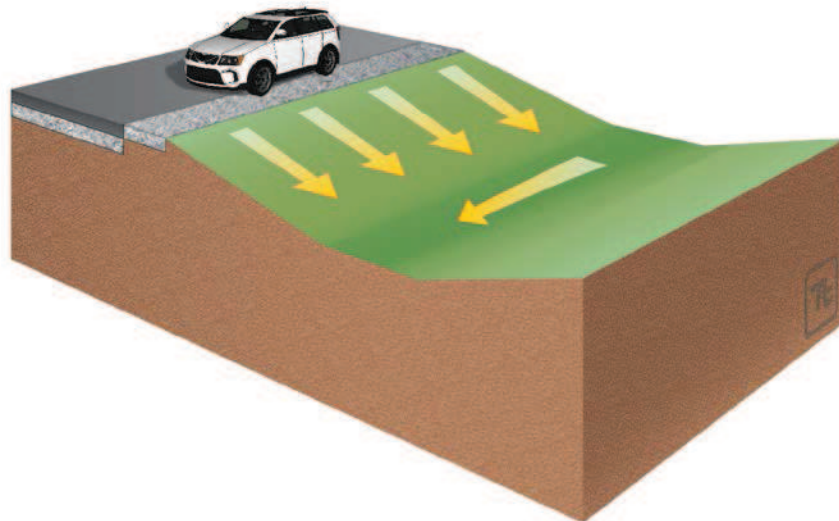

Notes: Arrows indicate water pathways.  
Image courtesy of Upper San Gabriel River Enhanced Watershed Management Program Plan.

### 4.3. NON-STORM WATER DISCHARGE CONTROL MEASURES

The overarching goal of BMPs in the EWMP is to reduce the impact of stormwater and non-stormwater on receiving water quality. The MS4 permit effectively prohibits non-stormwater discharges, and the SMB TMDL includes summer dry weather compliance requirements for bacteria in 2006 and winter dry in 2009. The SMB EWMP Group's dry weather compliance approach is to eliminate 100 percent of non-exempt dry weather MS4 discharges through a combination of the 23 existing LFDs along the J2/J3 EWMP area and a suite of non-structural source controls (e.g., water conservation incentives, enhanced Illicit Discharge Detection and Elimination (IDDE) efforts, and enhanced education/outreach and inspection/enforcement to address sources of non-stormwater flow) and source investigations following dry weather outfall screening. The primary mechanism to maintain compliance is the use of LFDs. These diversions are effectively eliminating non-stormwater surface discharges to the surf zone during dry weather days. Elimination of flows is equivalent to 100 percent load reduction for all pollutants, thereby demonstrating reasonable assurance of meeting all applicable Permit limitations during dry weather. Elimination of discharges is a pathway for compliance with RWLs and WQBELs in the MS4 permit (per section VI.E.2.e.i.(3)), without discharges there can be no "cause or contribute" to receiving water issues.

# Section 5

## EWMP Implementation Schedule

---

The EWMP Implementation Plan is the schedule for compliance for each jurisdiction to address water quality priorities and comply with the provisions of the MS4 Permit. Through the RAA, a series of quantitative analyses were used to identify the capacities of LID, green streets and regional BMPs that comprise the EWMP Implementation Plan and assure those control measures will address the Water Quality Priorities per the milestones/compliance schedules. The EWMP Implementation Plan provides a BMP-based compliance pathway for each jurisdiction under the MS4 Permit. This section describes the EWMP Implementation Plan and the pace of its implementation in order to achieve applicable milestones, and is organized into the following subsections:

- Compliance Schedule of Stormwater Control Measures
- Stormwater Control Measures to be Implemented by 2018 for Bacterial Milestone Compliance
- Stormwater Control Measures to be Implemented by 2021 for Bacterial TMDL Compliance
- Other Constituents and TMDL Compliance
- Summary of Permittee Actions

### 5.1. COMPLIANCE SCHEDULE OF STORMWATER CONTROL MEASURES

As described in Section 2 of the EWMP, scheduling of control measure implementation is based on the milestones of the SMB Beaches TMDLs, as follows:

- Bacteria
  - Milestone 1: Achieve 10% of the reduction for wet weather bacteria (2009 - achieved)
  - Milestone 2: Achieve 25% of the reduction for wet weather bacteria (2013- achieved)
  - Milestone 3: Achieve 50% of the reduction for wet weather bacteria (2018)
  - Milestone 4: Achieve 100% of the reduction for wet weather bacteria (2021)
- Debris
  - Milestone 1: Achieve 20% of the reduction for debris (2016)
  - Milestone 2: Achieve 40% of the reduction for debris (2017)
  - Milestone 3: Achieve 60% of the reduction for debris (2018)
  - Milestone 4: Achieve 80% of the reduction for debris (2019)
  - Milestone 5: Achieve 100% of the reduction for debris (2020)
- DDT
  - Compliance is to be demonstrated through CIMP monitoring and data analysis
- PCB
  - Compliance is to be demonstrated through CIMP monitoring and data analysis

### 5.2. STORMWATER CONTROL MEASURES TO BE IMPLEMENTED BY 2018 FOR BACTERIAL MILESTONE COMPLIANCE

In order to demonstrate reasonable assurance, BMPs were identified in a prioritized manner. Prioritization was based on cost (low cost BMPs were prioritized); BMP effectiveness for the pollutants of concern, and implementation feasibility as determined by desktop screening. Non-structural BMPs typically were prioritized higher over structural BMPs due to their lower relative cost.

The interim compliance deadline for the SMB Beaches TMDL requires a 50 percent reduction in exceedance days; this will be met by achieving 50 percent of the TLR in each CML analysis region, through a combination of non-structural, distributed green streets BMPs, existing centralized/regional BMPs and fast-tracked centralized/regional BMPs. Assuming a phased implementation, that can be controlled by the Permittee, it was assumed that 50 percent of the proposed distributed green streets BMPs would be implemented in all CML analysis regions between 2015 and 2018, and 50 percent would be implemented between 2018 and 2021.

In CML analysis regions that needed additional load reductions beyond the default to meet the interim targets, the implementation of a higher relative percentage (greater than 50 percent) of distributed BMPs before 2018 was prioritized first, and fast-tracking specific-planned or proposed regional BMPs were prioritized second. In CML analysis regions where no distributed green streets BMPs are necessary to meet the final compliance deadlines, regional BMPs were prioritized to reduce redundant load reductions. However, in CML analysis region 2-11, a small number of distributed green streets BMPs (5 percent of single family and commercial areas) was added rather than fast-tracking the large-scale regional projects, which would meet the interim and final targets. Alternatively, if the regional projects could be fast-tracked to be operable by 2018, then no distributed green streets BMPs would be required. The incremental load reduction between Penmar Phase I (existing) and Penmar Phase II (planned) that can be considered is negligible. Therefore, the full load reduction applicable to Penmar Phase II has been applied to the interim compliance deadline/target. **Table 5-1** lists projects that must be completed by 2018 to meet the milestone TLRs in all CML analysis regions. **Figure 5-1** illustrates the runoff to be retained in the critical year by 2018 to meet and be in compliance with the SMB Beaches TMDL. Further detailed scheduling for each jurisdiction, including stormwater volumes to be managed and control measure capacities, presented in **Appendix A**. Every jurisdiction has a standalone recipe for each assessment area/watershed.

# EWMP Implementation Costs and Financial Strategy

**Table 5-1**  
**Summary of Regional and Centralized BMPs Required Compliance in 2018**

Sub-watershed	Regional/Centralized BMP Identifier	Permittee <sup>1</sup>	BMP Status	Type	Volume (ft <sup>3</sup> )
2-07	RBMP47 – Riviera	LA	Planned	Infiltration	2,600,000
2-07	RBMP43 – Old Oak Rd	LA	Existing	Bioswale	48,343
3-01	RBMP31 - Roosevelt Elem	SM	Proposed	Infiltration	196,000
3-02	RBMP32 – Reed Park	SM	Proposed	Infiltration	192,000
3-03	RBMP16a - Clean Beaches Pier	SM	Planned	Infiltration	160,000
3-04	RBMP53 – SMHS Built	SM	Existing	Infiltration	40,000
3-05	RBMP37 - 3-5 Parking Lot	SM	Proposed	Infiltration	409,000
3-06	RBMP13 - Ozone	SM	Proposed	Infiltration	105,000
3-06	RBMP10 – Penmar Ph2	LA	Planned	Infiltration	371,000
3-07	RBMP01b – Grand Blvd IMF	LA	Existing	Media Filter	NA
3-07	RBMP21b – Grand Blvd IIMF	LA	Existing	Media Filter	NA
3-07	RBMP03 - Westminster	LA	Existing	Infiltration	1,460
3-09	RBMP18 – Crescent Bay	SM	Proposed	Infiltration	34,300
2-13	RBMP02 – Imperial Hwy	ES	Existing	Infiltration	54,800
2-13	RBMP42 – Imperial Strip	ES	Planned	Bioswale	NA
2-13	RBMP50 - Recreation85	ES	Proposed	Infiltration	94,400
2-15	RBMP49 - PumpStationB85	ES	Proposed	Infiltration	1,290,000

<sup>1</sup> LA = Los Angeles, SM = Santa Monica, ES = El Segundo

**Figure 5-1**  
**BMP Runoff Retained over Critical Year by Permittee by 2018**

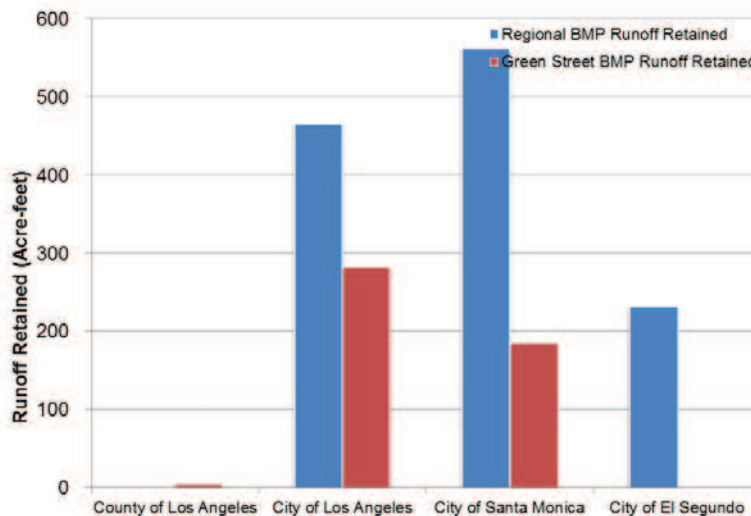

## 5.3. STORMWATER CONTROL MEASURES TO BE IMPLEMENTED BY 2021 FOR BACTERIAL MILESTONE COMPLIANCE

At the time of the final 2021 compliance deadline, a 42 percent load reduction is estimated, which is greater than the TLR of 35 percent. The load reduction attributable to individual regional BMPs in each CML analysis region is provided in **Appendix A** (Attachment E). The 2021 compliance deadline will be met by achieving 100 percent of the TLR in each CML analysis region, through a combination of non-structural BMPs, distributed green streets BMPs, existing centralized/regional BMPs and fast-tracked centralized/regional BMPs.

**Table 5-2** lists projects that must be completed by 2021 to meet the milestone TLRs in all CML analysis regions. **Figure 5-2** illustrates the runoff to be retained in the critical year by 2021 to meet and be in compliance with the SMB Beaches TMDL.

It should be noted that if at any time specific distributed green streets or regional/centralized BMPs are found to be infeasible for implementation, then alternative BMPs or operational changes will be planned within the same CML analysis region and within the same timeline, in order to meet an equivalent CML analysis region load reduction. **Table 5-3** and **Table 5-4** present a summary of the regional and Green Street BMP runoff retained, respectively.

**Figure 5-2**  
**BMP Runoff Retained over Critical Year by Permittee by 2021**

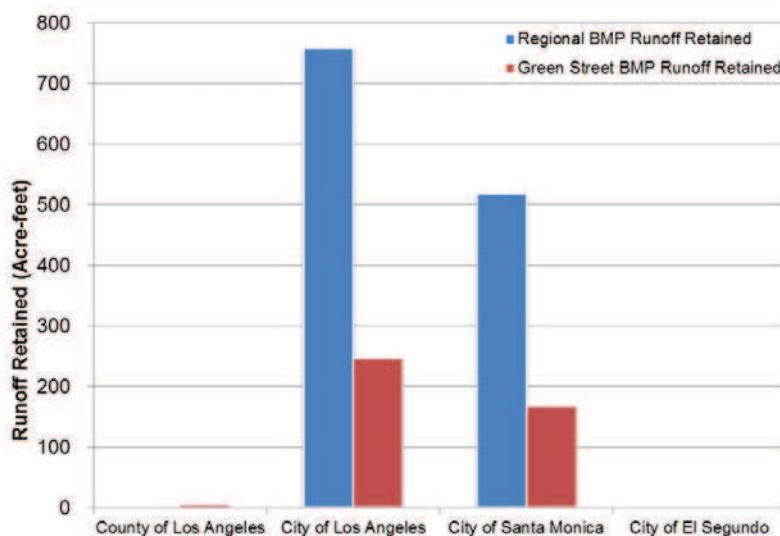

## EWMP Implementation Costs and Financial Strategy

**Table 5-2**  
**Summary of Regional and Centralized BMPs Required Compliance in 2021**

Sub-watershed	Regional/Centralized BMP Identifier	Permittee <sup>1</sup>	BMP Status	Type	Volume (ft <sup>3</sup> )
2-02	RBMP20 – Santa Ynez	LA	Planned	Infiltration	131,000
2-02	RBMP23 - 2-2 Parking Lot	LA	Proposed	Infiltration	134,000
2-06	RBMP08 - Temescal	LA	Planned	Infiltration	241,000
2-07	RMBP40b – Riviera Barranca SW	LA	Proposed	Bioswale	NA
2-07	RBMP17 - Mandeville	LA	Planned	Infiltration	136,000
2-07	RBMP48 – Rustic Canyon	LA	Proposed	Infiltration	40,400
3-01	RBMP29 – San Vicente Median	SM	Proposed	Infiltration	144,000
3-01	RBMP30 - Goose Egg Park	SM	Proposed	Infiltration	29,400
3-02	RBMP33 – Lincoln Middle School	SM	Proposed	Infiltration	128,000
3-04	RBMP44_Brentwood CC	LA	Planned	Infiltration	184,000
3-04	RBMP51_Memorial Park	SM	Proposed	Infiltration	402,000
3-04	RBMP52_SM Civic Auditorium	SM	Proposed	Infiltration	197,000
3-04	RBMP16b - Clean Beaches Park	SM	Planned	Infiltration	10,700
3-04	RBMP11 – Los Amigos	SM	Proposed	Infiltration	261,000
3-06	RMBP38 – Olympic High	SM	Proposed	Infiltration	86,000
3-06	RMBP39_Will Rodgers Elem	SM	Proposed	Infiltration	103,000
3-07	RBMP45 – Oakwood 85	LA	Planned	Infiltration	34,300
2-11	RBMP19 – Westchester Park	LA	Planned	Infiltration	823,000
2-11	RBMP09 – Westchester LAX	LA	Planned	Infiltration	802,000

<sup>1</sup>LA = Los Angeles, SM = Santa Monica, ES = El Segundo

**Table 5-3**  
**Regional BMP Capacity Required for Compliance (Acre-feet)**

Milestone	County of Los Angeles	City of Los Angeles	City of Santa Monica	City of El Segundo
<b>2018</b>	0.0	465.3	562.5	1260.0
<b>2021</b>	0.0	758.9	518.3	1277.2
<b>Total</b>	0.0	1224.2	1080.8	2537.2

**Table 5-4**  
**Green Street BMP Capacity Required for Compliance (Acre-feet)**

Milestone	County of Los Angeles	City of Los Angeles	City of Santa Monica	City of El Segundo
<b>2018</b>	4.8	283.3	184.5	0.0
<b>2021</b>	4.6	246.6	166.2	0.0
<b>Total</b>	9.4	529.9	350.7	0.0

### **5.4. OTHER IMPLEMENTATION ACTIVITIES FOR TMDL COMPLIANCE**

Listed below are subject activities that Permittees are responsible for during the implementation process.

#### **5.4.1. Non-Structural BMPs**

Non-structural BMPs include a combination of bacteria-targeted, wet weather source control BMPs that the SMB EWMP agencies are committed to implementing, such as pet waste controls, human waste source tracking, enhanced street sweeping, increased catch basin and storm drain cleaning, and other new or enhanced non-structural BMPs that target the pollutants addressed in this EWMP. Permittees are responsible for continued development, execution, enforcement, and reporting of the progress of these programs in their annual reports.

#### **5.4.2. Public Retrofit Incentives for BMPs**

These programs are directed at incentivizing the public to decrease the amount of stormwater runoff from their property. Permittees are responsible for continued development, execution, enforcement, and reporting of the progress of these programs in their annual reports.

#### **5.4.3. Non-stormwater Control Measures**

The objective of the EWMP is to reduce the impact of stormwater and non-stormwater on receiving water quality. The Permit effectively prohibits non-stormwater discharges and the SMB TMDL includes summer dry weather compliance requirements for bacteria since 2006 and winter dry compliance since 2009. Consistent with the Permit, The SMB EWMP Group's dry weather compliance approach is to eliminate 100 percent of non-exempt dry weather MS4 discharges through a combination of existing LFDs and a suite of non-structural source controls and source investigations when needed.

The primary mechanism to maintain compliance is the use of LFDs. These diversions are effectively eliminating non-stormwater surface discharges to the surf zone during dry weather days (MWH Team B, 2014). By eliminating flows, this is equivalent to 100 percent load reduction for all pollutants, thereby demonstrating reasonable assurance of meeting all applicable Permit limitations during dry weather. Elimination of discharges is a pathway for compliance with RWLs and WQBELs in the MS4 permit (per section VI.E.2.e.i.(3)); without discharges there can be no "cause or contribute" to receiving water issues. Implementaiton of additional non-storm water discharge is not applicable at this time.

### **5.5. OTHER CONSTITUENTS AND TMDL COMPLIANCE**

Compliance with the debris TMDL will be met through a phased retrofit of appropriate catch basins and other strategic in-line storm drain locations throughout the SMB EWMP area in order to meet each interim compliance milestones deadline (20% load reduction per year between 2016 and 2019) as well as the final compliance deadline (100% load reduction) in 2020. Consistent with the City's Trash Monitoring and Reporting Plan (TMRP) (City of Los Angeles Department of Public Works, 2012), "vertical insert[s] with 5-mm openings and flow activated opening screen covers are the best suited for implementation within the City to achieve compliance with Trash TMDLs".

The SMB TMDL for DDTs and PCBs developed waste load allocations (WLAs) for stormwater throughout the SMB watershed. Because the SMB EWMP group area contribution is not distinctly defined in the TMDL, the WLAs assigned to the entire SMB WMA as a whole are being used for this discussion. The existing TMDL-estimated loads for all of SMB and most of the individual watersheds are lower than the maximum allowable loads. Therefore, consistent with the TMDL, it is assumed that there

---

## EWMP Implementation Costs and Financial Strategy

---

is a zero load reduction required for PCBs and DDTs in MS4 discharges, and reasonable assurance is demonstrated.

As part of the adaptive management process, based on monitoring data collected through the approved CIMP, additional structural and/or non-structural BMPs may be proposed if needed. Additionally, if the loads are found to be higher than estimated, but still less than the maximum allowable loads, there may be potential for the WLA to be revised.

### 5.6. SUMMARY OF PERMITTEE ACTIONS

Permittee actions can be categorized into three groups: project implementation, continued water quality monitoring, and reporting of monitoring results and progress.

**Project Implementation:** The rate of project implementation required for milestone and TMDL compliance is rapid. Permittees must implement projects within the RAA, listed in **Table 5-1** and **Table 5-2**, by their associated construction date. Implementation of EWMP projects will have numerous actions, too many to list, including associated project planning, funding, permitting, design, construction, and operation.

**Water Quality Monitoring:** Permittees shall continue TMDL monitoring as specified in the TMDLs. Monitoring and reporting of the results are currently a Permittee action. The monitoring will primarily be used to ensure compliance; however, monitoring may also assist in the development of adaptive management if unforeseen water quality changes occur.

**Reporting:** Permittees shall continue TMDL reporting. Preparation of an annual report for compliance with TMDLs is currently a Permittee action, although this action will be expanded to include progress towards implementation of projects for milestone and TMDL compliance. Annual reports shall be amended to include the following:

- Non-Structural BMPs – update on program development, execution, and enforcement.
- Public Retrofit Incentives – update in development, execution, and enforcement.
- Green Street BMP Project Implementation – provide an update on the Green Street BMP projects in planning, design, and construction. Each project should have an associated capacity. The current and planned green street BMP shall be reported and reconciled with the RAA modeled required green street BMP capacity for compliance. Deviations from the planned projects will be reported and the calculated BMP capacity documented.
- Regional BMP Project Implementation – provide an update on the regional BMP projects in planning, design, and construction. Each project should have an associated capacity. The current and planned regional BMP capacity shall be reported and reconciled with the RAA modeled required capacity for compliance. Deviations from the planned projects will be reported and the calculated BMP capacity documented.

# Section 6

## Assessment and Adaptive Management Framework

---

### 6.1 ADAPTIVE MANAGEMENT PROCESS

The EWMP is intended to be implemented as an adaptive program. As new program elements are implemented and information is gathered over time, the EWMP will undergo modifications to reflect the most current understanding of the watershed and present a sound approach to addressing changing conditions. As such, the EWMP will employ an adaptive management process that will allow the EWMP to evolve over time.

Part VI.C.8 of the Permit details the adaptive management process to be included in the EWMP that includes the following requirements:

- i. Permittees shall adapt the EWMP every two years to become more effective from the date of program approval based on, but not limited to a consideration of:
  - (1) progress toward achieving WQBELs and/or RWLs;
  - (2) Permittee monitoring data;
  - (3) achievement of interim milestones;
  - (4) re-evaluation of water quality priorities and source assessment;
  - (5) non-Permittee monitoring data;
  - (6) Regional Board recommendations; and
  - (7) Recommendations through a public participation process.
- ii. Permittees shall report any modifications to the EWMP in the annual report.
- iii. Permittees shall implement any modifications to the EWMP upon approval by the Regional Board or within 60 days of submittal if the Regional Board expresses no objections.

The adaptations to the EWMP, if and when necessary, as called for in the adaptive management process, essentially include: 1) re-characterization of water quality priorities, 2) a source assessment re-evaluation, 3) an effectiveness assessment of watershed control measures, and 4) an updated RAA. The CIMP will gather additional data on receiving water conditions and stormwater/non-stormwater quality to inform these analyses. This management process will be implemented and repeated every two years as part of the adaptive management process. Each of these adaptations are described in the following subsections.

#### 6.1.1. Re-Characterization of Water Quality Priorities

Water quality within the SMB EWMP Group area will be re-characterized using data collected as a result of the CIMP implementation to include the most recent data available. WBPC classifications may be updated as a result of changing water quality conditions. These WBPCs will be important for refocusing water quality improvement efforts and informing the selection of future watershed control measures.

### **6.1.2. Source Assessment Re-Evaluation**

The assessment of possible sources of water quality pollutants will be re-evaluated based on new information from the CIMP implementation. The identification of non-MS4 and MS4 pollutant sources is an essential component of the EWMP because it determines whether the source can be controlled by watershed control measures. As further monitoring is conducted and potential sources are better understood, the source assessment becomes more accurate and informed.

### **6.1.3. Effectiveness Assessment of Watershed Control Measures**

The evaluation of BMP effectiveness is an important part of the EWMP adaptive management process. Implementation of the CIMP will provide a quantitative assessment of structural BMP effectiveness as it relates to actual pollutant load reduction to determine how selected BMPs have performed at addressing established water quality priorities. The effectiveness assessment of watershed control measures becomes important for the selection of future control measures to be considered.

### **6.1.4. Update of Reasonable Assurance Analysis**

The data gathered as a result of the CIMP will support adaptive management at multiple levels, including 1) generating data not previously available to support model updates, and 2) tracking improvements in water quality over the course of EWMP implementation. As described in **Section 3**, the RAA is an iterative process that depends on the continuous refinement and calibration of the watershed model used.

## **6.2 REPORTING**

Annual reporting will be completed each year as part of the CIMP. In addition to assessing the overall progress of the WMP, the CIMP reporting will detail the implemented BMPs and demonstrate the cumulative BMP capacities to achieve the interim targets. Data obtained through CIMP monitoring will be used to determine the overall effectiveness of the EWMP and the next phases of EWMP implementation during the adaptive management process.

# Section 7

## EWMP Implementation Costs and Financial Strategy

---

This section identifies the estimated order-of-magnitude cost of the activities, and potential funding options that the SMB EWMP Group will be pursuing to fund the program. Major investments in the watershed will be required, particularly for the construction of structural BMPs, but the program will bring many benefits: water quality, clean beaches, stormwater and rainwater harvesting for infiltration and offset of potable water use, creation of new green space, and neighborhood enhancements. These benefits are important, but the monetary value is difficult to determine. Although the definition of a financial strategy varies across industries, within the context of the EWMP, the financial strategy is interpreted to represent the strategic options available to the Permittees for financing program costs associated with the new MS4 Permit.

Currently, a funding source for all of the activities described in this EWMP has not been determined. Nevertheless, this section identifies the estimated order-of-magnitude cost of the activities, the amount of funding currently available to meet the needs described in the EWMP, and potential funding sources that may be available. This section is intended to serve as a high-level financial strategy by addressing the following items:

- Documentation of estimated program costs by BMPs;
- Assessment of Impact of program costs on Permittees;
- Review of existing policies, revenues, and costs affecting stormwater;
- Identification of financial strategies for financing program costs; and
- Identification of future steps needed to implement the financial strategy.

### 7.1. EWMP COSTS

The purpose of this section is to present order-of-magnitude cost estimates to implement the EWMP. Estimated program costs were developed using the methodology described in **Appendix B**. Program costs consist of expenses that must be borne by the co-Permittees in order to comply with the Permit requirements.

Costs were derived using an RAA that includes the identification and evaluation of BMPs to be used in order to achieve applicable WQBELS and RWLs. This approach identifies a variety of watershed BMPs including LID, green streets, and regional projects. Costs were developed using unit costs of similar stormwater BMPs described in the *Multi-Pollutant TMDL Implementation Plan for the Unincorporated County Area of Los Angeles River Watershed* (LACDPW, 2010). Select unit costs were modified based on recent construction experience for similar projects.

For structural BMP projects, costs are included for planning, design, permits, construction, operation and maintenance (O&M), and post-construction monitoring, where applicable. The O&M costs represent present value of the estimated costs over a 20-year period. Unit costs for major construction components are presented in **Table 7-1**. To the extent possible, BMPs have been located on publicly-owned land to reduce land acquisition costs. Estimated costs are based on model results; however, real costs will depend on monitoring results and the outcome of the adaptive management process. As a result, it is emphasized

## EWMP Implementation Costs and Financial Strategy

that these estimated costs are preliminary and have the potential to be reduced through the adaptive management process.

**Table 7-1  
Conceptual Design Major Components Unit Cost**

Construction Component	Unit Cost
Mobilization <sup>1</sup>	10% of construction total
Site Preparation <sup>1</sup>	\$6,000 per acre
Excavation and Removal	\$30.00 per cubic yard
Asphalt/Base Removal	\$9.60 per cubic yard
Reinforced Concrete Pipe <sup>1</sup>	\$16.00 per diameter (inch) per length (foot)
Gravel Sub-base	\$63.00 per cubic yard
Backfill Material <sup>1</sup>	\$20.00 per cubic yard
Landscaping <sup>1</sup>	\$5.00 - \$25.00 per square foot
60-inch Corrugated Metal Pipe <sup>2</sup>	\$150,000 per acre-foot
Planning/Project Management <sup>1</sup>	20% of total construction costs
Design and Permitting (Centralized) <sup>1</sup>	15% of total construction costs
Contingency for Planning Estimate (Centralized)	25% of total construction costs

Notes:

<sup>1</sup> Unit costs have been modified from TMDL Implementation Plan based on recent construction experience for similar projects.

<sup>2</sup> Material costs for the 60-inch CMP used in subsurface infiltration basins were provided by Contech Engineering Solutions. Costs include CDS pretreatment.

The costs for structural BMPs are considered to be planning level only (order of magnitude), and can be refined as implementation of the EWMP progresses, using actual BMP implementation costs. Costs for enhanced minimum control measures and other institutional BMPs have not been included because they will vary by jurisdiction and are estimated to be a small percentage of the overall program costs.

### 7.1.1. EWMP Costs by BMP and TMDL Milestones

Based on the RAA, a set of optimal BMPs were derived, having reasonable assurance of meeting the interim and final limitation milestones set forth by the Regional Board. Total estimated BMP costs are shown in **Table 7-2**. Capital costs and O&M costs are based on a 20-year implementation cost schedule. The 20-year implementation cost schedule relies on initial capital costs and recurring annual O&M costs for each specific type of BMP over a 20-year time frame. Additionally, estimated capital costs have been developed for each TMDL milestone and are presented along with the expected annual O&M costs for that milestone in **Table 7-2**.

# EWMP Implementation Costs and Financial Strategy

**Table 7-2  
Total Costs by Milestone (\$ Millions)<sup>1</sup>**

Agency	Program	Present to Milestone 1 <sup>2</sup>		Milestone 1 to Milestone 2 <sup>3</sup>	
		Capital	O&M/year	Capital	O&M/year
Los Angeles	Streets	\$188.4	\$6.2	\$140.2	\$9.0
	Regional	\$5.7		\$74.5	
Santa Monica	Streets	\$85.5	\$4.9	\$63.1	\$5.6
	Regional	\$22.3		\$42.4	
Uninc. LA County	Streets	\$3.1	\$0.09	\$2.7	\$0.09
	Regional	-		-	
El Segundo	Streets	\$0.0016	\$0.96	-	\$1.1
	Regional	\$20.8		-	
Total		\$325.8	\$12.2	\$322.9	\$15.8

<sup>1</sup> O&M costs for each milestone includes cost from previous milestone (i.e. the costs are cumulative)

<sup>2</sup> Milestone 1 represents the 2018 Interim TLR deadline

<sup>3</sup> Milestone 2 represents the 2021 Final TLR deadline

## 7.1.2. EWMP Costs by Watershed

Similar to EWMP costs described in **Section 7.1.1**, the total BMP costs were identified by jurisdiction (City or Agency) and watershed as shown in **Table 7-3**.

**Table 7-3  
Total Costs by Agency (\$ Millions)**

Agency	Capital	O&M <sup>1</sup>
Los Angeles	\$408.8	\$54.2
Santa Monica	\$213.2	\$33.5
Uninc. LA County	\$5.9	\$0.53
El Segundo	\$20.8	\$6.42
Total	\$648.7	\$94.7

<sup>1</sup> O&M cost is the present worth value of an annual O&M cost over a lifespan of 20 Years with a 5% interest.

## 7.2. IMPACT OF EWMP COSTS

The EWMP costs will have a significant financial impact on all Permittees. In order to determine the financial impact to each Permittee, a high-level calculation was conducted by dividing the costs by the total number of parcels in the watershed. There are a total of 64,971 parcels within SMB, resulting in a capital cost of \$10,012 per parcel. It is important to note that this preliminary estimate is for planning purposes only. As parcels are not uniform throughout the cities, the final cost will be dependent on a number of other factors.

## 7.3. EXISTING STORMWATER PROGRAMS

Even though the Regional Board only implemented Order No R4-2012-0175, NPDES No CAS00401 on November 2012, the SMB EWMP Group has been addressing stormwater discharge prior to November 2012 with existing recurring costs associated with these activities in excess of \$50 million annually.

## EWMP Implementation Costs and Financial Strategy

**Table 7-4** provides a summary of existing costs and associated revenue source by jurisdiction. It is assumed that these recurring costs will continue into the future and the costs for implementing the activities outlined in this EWMP are in addition to these costs.

**Table 7-4  
Existing Stormwater Costs**

Jurisdiction	Existing Utility?	Funding Source	Description of Costs	Total Costs
	(Yes/No)			(\$)
Los Angeles	Yes	Stormwater Fund	O&M and Capital, Planning, Enforcement and Monitoring	~\$30M/yr (City Wide; not including Prop O)
Santa Monica	Yes	Stormwater and Clean Beaches Fund	O&M and Capital, Outreach, Inspections, Management	~\$13.7M/yr
Unincorporated LA County	Yes	General Fund	Management, Outreach, inspection, enforcement, monitoring	~80M/yr (County-wide)
El Segundo	No	To Be Determined	To Be Determined	To Be Determined

### 7.4. FINANCIAL STRATEGIES

The financial strategy described in this section is focused on developing a set of options to address the expected additional costs associated with compliance with the new MS4 Permit. It is not intended to incorporate the costs associated with existing stormwater activities identified previously. Just as the engineering and strategic solutions for watershed management rely upon a coordinated regional approach, so too does the financial strategy. Capital and operating costs for watershed programs are large and span decades. As such, there is no single “right” way to finance these programs. Instead, the financial strategy presented herein outlines a set of multiple approaches, allowing each jurisdiction to select those strategies that best fit their specific circumstances.

The detailed financial strategies for the EWMP costs will be highly dependent on a variety of factors and vary by jurisdiction. Each Permittee has different resources; therefore, each Permittee will use a different set of options at its disposal. High-level alternatives that can be examined as each Permittee moves forward as a group or as individuals are described below. Acknowledgement is given to Stormwater Funding Options – Providing Sustainable Water Quality Funding in Los Angeles County, a report authored by Ken Farfsing and Richard Watson dated May 21, 2014.

### **7.4.1. Grants**

Financial strategies available to the Permittees associated with grants include:

- Apply for grants through the recently passed Prop 1 – 2014 Water Bond. Over \$400M is available for stormwater capture, Integrated Regional Watershed Management Plans (IRWMP), and urban creek restoration projects.
- Apply for grants available through the Integrated Regional Water Management (IRWM) grant program - \$251 million dollars will be awarded in 2016 to fund planned or partially completed local and regional projects that increase local reliability. Examples of qualifying projects include stormwater recapture, expansion of recycled water distribution, and enhancement of groundwater storage management, among others.
- Apply for grants under Section 319 of Clean Water Act, which authorizes the USEPA to develop a program aimed at implementing nonpoint source management programs.
- Apply for competitive grants.
- Apply for other grants (state and federal) for stormwater improvement, beach water quality improvement, and green infrastructure projects. (e.g. Prop. 84, CBI, TIGER, etc.).

### **7.4.2. Fees and Charges**

Financial strategies available to the Permittees that have fees and charges include:

- Use existing revenue streams for stormwater/water supply/flood control projects to support stormwater quality projects.
- AB 2403 – Use new state law to pass rate increase for stormwater projects that have a water supply benefit and minimize the Proposition 218 process.
- Use revenue generated from a Stormwater Impact Fee (or “In-Lieu” Fee) to comply with LID ordinances to fund mitigation bank for regional projects.
- Increase solid waste management fees to cover the cost of enhanced street sweeping and other measures to reduce trash for compliance with TMDLs.
- Consider adopting water conservation fees that would provide funding for reducing irrigated runoff in order to both conserve groundwater and reduce dry weather runoff pollution.
- Continue to pursue a county-wide stormwater parcel fee initiative, which could be tied to AB 2403 as well.
- Consider assessments on car rentals since some of the pollution in our waterways is from cars driven on local streets.

### **7.4.3. Legislative and Policy**

Financial strategies available to the Permittees that require legislative or policy changes are summarized below:

- Develop stormwater retention credit trading market to use private equity.
- Ask the Metropolitan Water District of Southern California (MWD) to reevaluate their approach for managing the Local Resource Program (LRP) to fund stormwater capture and use projects that offset the use of imported water supplies.
- Pursue pollutant source control legislation patterned after SB 346 that either limits pollutants of concerns in products (e.g. copper in brake pads, or zinc in tires) or assesses a fee on those products that can be used by local governments to mitigate those pollutants.
- Form Special Assessment Districts and fees tailored to the Watershed Management Groups.

---

## **EWMP Implementation Costs and Financial Strategy**

---

- Explore the use of Enhanced Infrastructure Finance Districts tailored to the Watershed Management Group, as outlined in recently adopted (2014) California legislation SB628.
- Explore 2014 Water Resources Reform and Development Act of 2014 (WRRDA) and funding opportunities.

### **7.4.4. Future Steps**

The financial strategies described herein are options for funding sources, some or all of which will need to be implemented to develop a comprehensive financial solution. As each Permittee determines the appropriate funding source(s), they will also need to consider the following items:

- Development of public support for financial strategies through outreach efforts;
- Creation of inter-jurisdiction watershed management group and EWMP financial working group; and
- Development of a more formal Stormwater Program Financial Plan, which would potentially include the following components:
  - Implementation of new fee or charge;
  - Establishment of new enterprise fund;
  - Cash and debt financing;
  - Operating and capital reserves; and
  - Cash flow modeling.

The SMB EWMP Group as a whole, as well as individual members, are currently prioritizing and selecting the specific financing strategies that best fit their needs. It is anticipated that a more fully developed financial plan will be developed and implemented by the group and/or its individual members in the coming months and years that incorporates elements of the financial strategy described in this section and implements future steps identified above.

# Section 8

## Legal Authority

---

As required on page 39 of the Standard Provisions of the Permit, each Permittee must maintain the legal authority to implement the provisions of the Permit consistent to the Annual Report submittals. **Appendix E** includes copies of the legal authority certification.

# Section 9

## References

---

- CASQA, 2006. “An Introduction to Stormwater Program Effectiveness Assessment.” White Paper: [http://www.scvurpppw2k.com/pdfs/0405/CASQA%20White%20Paper\\_An%20Introduction%20to%20Stormwater%20Program%20Effectiveness%20Assessment4.pdf](http://www.scvurpppw2k.com/pdfs/0405/CASQA%20White%20Paper_An%20Introduction%20to%20Stormwater%20Program%20Effectiveness%20Assessment4.pdf).
- City of Los Angeles “Projects for 5-Year Expenditure plan – Santa Monica Bay, Ballona Creek, Marina Del Rey, Dominguez Channel.” Excel Database. Received November 2013.
- City of Los Angeles, Concept Memo #3: Reasonable Assurance Analysis Approach, December, 2013.
- City of Los Angeles. “City of Santa Monica BMPs – Private and City Owned.” Excel Database. Received November 2013.
- City of Los Angeles. “City of Santa Monica BMPs – City Owned.” Excel Database. Received November 2013.
- City of Los Angeles. “LA Sanitation Green Infrastructure Projects list.” Excel Database. December 2012. Received November 2013.
- City of Los Angeles. “Low Flow Development Project Information” Excel Database. January 1, 2008. Received November 2013.
- City of Los Angeles. “Santa Monica Bay Watershed Regional BMP Projects.” PDF Document. Received November 2013.
- City of Los Angeles. “Standard Urban Stormwater Mitigation Plan (SUSMP) LID Data ” Excel Database. June 2006 through September 2013. Received November 2013.
- City of Los Angeles. Concept Memos. MS Word Document Received. November, 2013
- City of Los Angeles. Concept Memos. November 2013.
- City of Malibu, 2012. Comment Letter – Bacteria TMDL Revisions for Santa Monica Bay Beaches. May 7, 2012.
- Ferguson, D.M., Moore, D.F., Getrich, M.A., and M.H. Zhouandai, 2005. “Enumeration and speciation of enterococci found in marine and intertidal sediments and coastal water in southern California.” *Journal of Applied Microbiology* 99(3).
- Geosyntec Consultants, RAA Technical Memorandum, March 2015.
- Geosyntec Consultants and Wright Water Engineers, 2012. International Stormwater Best Management Practices (BMP) Database Pollutant Category Summary Statistical Addendum: TSS, Bacteria, Nutrients, and Metals. July 2013.
- Geosyntec Consultants, 2012. A User’s Guide for the Structural BMP Prioritization and Analysis Tool (OCTA-SBPAT v1.0). Prepared for Orange County Transportation Authority. November 2012.
- Geosyntec Consultants, 2012. San Luis Rey River Watershed Comprehensive Load Reduction Plan. October.
- Grant, S.B., Sanders, B.F., Boehm, A.B., Redman, J.A., Kim, J.H., Mrse, R.D., Chu, A.K., Gouldin, M., McGee, C.D., Gardiner, N.A., Jones, B.H., Svejkovsky, J., Leipzig, G.V., and A. Brown, 2001.

- “Generation of Enterococci Bacteria in a Coastal Saltwater Marsh and its Impact on Surf Zone Water Quality.” *Environmental Science and Technology* 35(12).
- Griffith, J.F., 2012. “San Diego County Enterococcus Regrowth Study.” SCCWRP Technical Report.
- Helsel, Dennis R. *Nondetects and Data Analysis: Statistics for Censored Environmental Data*. Hoboken, NJ: Wiley-Interscience, 2005. Print.
- Imamura, G.J., Thompson, R.S., Boehm, A.B., and J.A. Jay, 2011. “Wrack promotes the persistence of fecal indicator bacteria in marine sands and seawater.” *FEMS Microbiology Ecology* 77(1).
- Izbicki, J, 2012a. “RE: MS#1092: Update submitted for “Sources of Fecal Indicator Bacteria to Groundwater, Malibu Lagoon, and the Near-Shore Ocean, Malibu, California.” “RE: USGS Study”. Email to Barbara Cameron. May 4, 2012 11:18 am.
- Izbicki, J., Swarzenski, P., Burton, C., and L.C. Van DeWerfhorst, 2012b. “Sources of fecal indicator bacteria to groundwater, Malibu Lagoon, and the near-shore ocean, Malibu, California.” Submitted 2012.
- Jiang, S., McGee, C., Candelaria, L., and G. Brown, 2004. “Swimmer Shedding Study in Newport Dunes, California. Final Report.” [http://www.waterboards.ca.gov/rwqcb8/water\\_issues/programs/tmdl/docs/swimmerreport.pdf](http://www.waterboards.ca.gov/rwqcb8/water_issues/programs/tmdl/docs/swimmerreport.pdf)
- Lee, C.M., Lin, T.Y., Lin, C.C., Kohbodi, G.A., Bhatt, A., Lee, R., and J.A. Jay, 2006. “Persistence of fecal indicator bacteria in Santa Monica Bay beach sediments.” *Water Research* 40(14).
- Litton, R.M., Ahn, J.H., Sercu, B., Holden, P.A., Sedlak, D.L., and S.B. Grant, 2010. “Evaluation of Chemical, Molecular, and Traditional Markers of Fecal Contamination in an Effluent Dominated Urban Stream.” *Environmental Science and Technology* 44(19).
- LACDPW, 2000. Los Angeles County 1994-2000 Integrated Receiving Water Impacts Report. July 31.
- LADPW. 2011-2012 Annual Stormwater Monitoring Report. <http://ladpw.org/wmd/npdesrsa/annualreport/index.cfm>
- Los Angeles Regional Water Quality Control Board (Regional Board), 2012. Order No. R4-2012-0175 NPDES Permit No. CAS004001 Waste Discharge Requirements for Municipal Separate Storm Sewer System (MS4) Discharges within the Coastal Watersheds of Los Angeles County, except those Discharges Originating from the City of Long Beach MS4. November 8. [http://www.waterboards.ca.gov/losangeles/water\\_issues/programs/stormwater/municipal/la\\_ms4/2012/Order%20R4-2012-0175%20-%20A%20Final%20Order%20revised.pdf](http://www.waterboards.ca.gov/losangeles/water_issues/programs/stormwater/municipal/la_ms4/2012/Order%20R4-2012-0175%20-%20A%20Final%20Order%20revised.pdf)
- Los Angeles Regional Water Quality Control Board (Regional Board), 2012. Regional Board Basin Plan Amendment for the Santa Monica Bay Beaches Bacteria TMDL. June 7, 2012. [http://www.waterboards.ca.gov/losangeles/board\\_decisions/basin\\_plan\\_amendments/technical\\_documents/90\\_New/Jan2013/Final%20BPA%20Attach%20A%20SMBB%20Dry&Wet%2007Jun12.pdf](http://www.waterboards.ca.gov/losangeles/board_decisions/basin_plan_amendments/technical_documents/90_New/Jan2013/Final%20BPA%20Attach%20A%20SMBB%20Dry&Wet%2007Jun12.pdf)
- Los Angeles Regional Water Quality Control Board (Regional Board), 2010. Proposed Amendments to the Water Quality Control Plan – Los Angeles Region for the Santa Monica Bay Nearshore and Offshore Debris TMDL. Attachment A to Resolution No. R10-010. Adopted November 4, 2010. [http://63.199.216.6/larwqcb\\_new/bpa/docs/R10-010/R10-010\\_RB\\_BPA.pdf](http://63.199.216.6/larwqcb_new/bpa/docs/R10-010/R10-010_RB_BPA.pdf)
- Los Angeles Regional Water Quality Control Board (Regional Board), 2005. Total Maximum Daily Load for Metals in Ballona Creek. July 7, 2005. [http://www.waterboards.ca.gov/losangeles/board\\_decisions/basin\\_plan\\_amendments/technical\\_documents/2005-007/05\\_0831/StaffReport.pdf](http://www.waterboards.ca.gov/losangeles/board_decisions/basin_plan_amendments/technical_documents/2005-007/05_0831/StaffReport.pdf)
- Los Angeles Regional Water Quality Control Board (Regional Board), 2002. Draft Santa Monica Bay Beaches Bacteria TMDL, Revised Staff Report (Dry Weather Only). January 14, 2002.

- [http://www.waterboards.ca.gov/losangeles/board\\_decisions/basin\\_plan\\_amendments/technical\\_documents/2002-004/02\\_0114\\_tmdl%20Dry%20Weather%20Only\\_web.pdf](http://www.waterboards.ca.gov/losangeles/board_decisions/basin_plan_amendments/technical_documents/2002-004/02_0114_tmdl%20Dry%20Weather%20Only_web.pdf)
- Los Angeles Regional Water Quality Control Board (Regional Board), 2002. Proposed Amendments to the Water Quality Control Plan – Los Angeles Region to incorporate the Santa Monica Bay Beaches Bacteria TMDL. Attachment A to Resolution No. 02-004. [http://63.199.216.6/larwqcb\\_new/bpa/docs/2002-004/2002-004\\_RB\\_BPA.pdf](http://63.199.216.6/larwqcb_new/bpa/docs/2002-004/2002-004_RB_BPA.pdf)
- Los Angeles Regional Water Quality Control Board (Regional Board), 2002. Proposed Amendments to the Water Quality Control Plan – Los Angeles Region to incorporate Implementation Provisions for the Region’s Bacteria Objectives and to incorporate the Santa Monica Bay Beaches Bacteria TMDL. Attachment A to Resolution No. 2002-022. [http://63.199.216.6/larwqcb\\_new/bpa/docs/2002-022/2002-022\\_RB\\_BPA.pdf](http://63.199.216.6/larwqcb_new/bpa/docs/2002-022/2002-022_RB_BPA.pdf)
- Los Angeles Regional Water Quality Control Board (Regional Board), 1995. Updated 2011. Water Quality Control Plan, Los Angeles Region. [http://www.waterboards.ca.gov/rwqcb4/water\\_issues/programs/basin\\_plan/index.shtml](http://www.waterboards.ca.gov/rwqcb4/water_issues/programs/basin_plan/index.shtml)
- Los Angeles Regional Water Quality Control Board (Regional Board), 2012. Order No. R4-2012-0175 NPDES Permit No. CAS004001 Waste Discharge Requirements for Municipal Separate Storm Sewer System (MS4) Discharges within the Coastal Watersheds of Los Angeles County, except those Discharges Originating from the City of Long Beach MS4. November 8. [http://www.waterboards.ca.gov/losangeles/water\\_issues/programs/stormwater/municipal/la\\_ms4/2012/Order%20R4-2012-0175%20-%20A%20Final%20Order%20revised.pdf](http://www.waterboards.ca.gov/losangeles/water_issues/programs/stormwater/municipal/la_ms4/2012/Order%20R4-2012-0175%20-%20A%20Final%20Order%20revised.pdf)
- MWH Team, 2014a. J2/J3 EWMP Work Plan, June.
- MWH Team, 2014b. J2/J3 CIMP, June.
- Online Project Tracking and Integration (OPTI) Database. <http://irwm.rmcwater.com/la/dashboard.php>
- Phillips, M.C., Solo-Gabriele, H.M., Piggot, A.M., Klaus, J.S., and Y. Zhang, 2011. “Relationships between Sand and Water Quality at Recreational Beaches”, *Water Resources* 45(20).
- Sabino, R., Verissimo, C., Cunha, M.A., Wergikowski, B., Ferreira, F.C., Rodrigues, R., Parada, H., Falcao, L., Rosado, L., Pinheiro, C., Paixao, E., and J. Brandao, 2011. “Pathogenic fungi: An unacknowledged risk at coastal resorts? New insights on microbiological sand quality in Portugal.” *Marine Pollution Bulletin* 62: 1506-1511.
- SCCWRP, 2005. Microbiological Water Quality at Reference Beaches in Southern California during Wet Weather (SCCWRP Technical Report 448). August.
- SCCWRP, 2007a. Assessment of Water Quality Concentrations and Loads from Natural Landscapes (SCCWRP Technical Report 500). February.
- SCCWRP, 2007b. Sources, Patterns and Mechanisms of Storm Water Pollutant Loading From Watersheds and Land Uses of the Greater Los Angeles Area, California, USA (SCCWRP Technical Report 510). March.
- Stein, E.D., Tiefenthaler, L.L., and Schiff, K.C., 2007. “Sources, Patterns and Mechanisms of Storm Water Pollutant Loading From Watersheds and Land Uses of the Greater Los Angeles Area, California, USA.” Southern California Research Project (SCCWRP), Technical Report 510, March.
- Tiefenthaler, L., Stein, E.D., and K.C. Schiff, 2011. “Levels and patterns of fecal indicator bacteria in stormwater runoff from homogenous land use sites and urban watersheds.” *Journal of Water and Health* 9:279-290.
- U.S. Department of Agriculture (USDA), 2009. National Engineering Handbook (210-VI-NEH), Chapter 7. Natural Resource Conservation Service.

- United States Environmental Protection Agency (USEPA), 1993. Subsurface Flow Wetlands for Wastewater Treatment, A Technology Assessment. July 2013.
- United States Environmental Protection Agency (USEPA), 2012. Santa Monica Bay Total Maximum Daily Loads for DDTs and PCBs.
- Ventura County Flood Control District, 2003. Stormwater monitoring report, 1997- 2003.
- Weisberg, S.B., and D.M. Ferguson, 2009. “North Santa Monica Bay Source Investigation Study, Ramirez Creek and Escondido Creek, Malibu, 2009 Summary and Recommended Studies.” SCCWRP.
- Weston Solutions, 2010. “Tecolote Creek Microbial Source Tracking Summary – Phases I, II, and III.”
- Wright Water Engineers (WWE) and Geosyntec Consultants, 2007. FAQ: Why does the International Stormwater BMP Database Project omit percent removal as a measure of BMP performance? <http://www.bmpdatabase.org/Docs/FAQPercentRemoval.pdf>.