

CITY OF LOS ANGELES



**SANITATION**  
DEPARTMENT OF  
PUBLIC WORKS

WATERSHED PROTECTION DIVISION  
DEPARTMENT OF PUBLIC WORKS  
BUREAU OF SANITATION  
CITY OF LOS ANGELES

# **Catch Basin Inserts: Method to Determine CB Inserts Act as Full Capture Devices**

---



# Catch Basin Inserts: Method to Determine CB Inserts Act as Full Capture Devices

## Background

The intent of this paper is to present a method to determine if the existing configurations of the City of Los Angeles' catch basin (CB) inserts with 5 millimeter openings meet the definition of a full capture device as defined in the Trash Total Maximum Daily Loads (TMDLs) documents.

The City has explored several configurations of catch basin inserts in order to select one that met the regulatory requirements and had minimal impact on its existing storm drain system. Figure 1 below shows the evolution of CB inserts that the City investigated during the past 4 years.

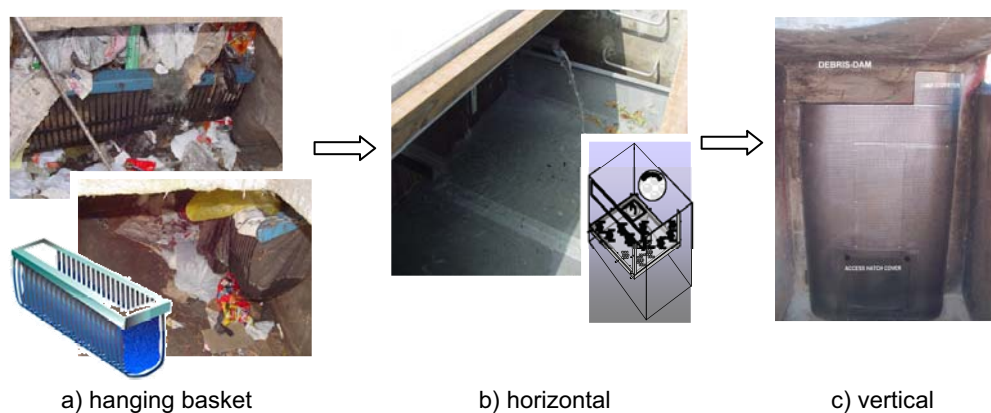
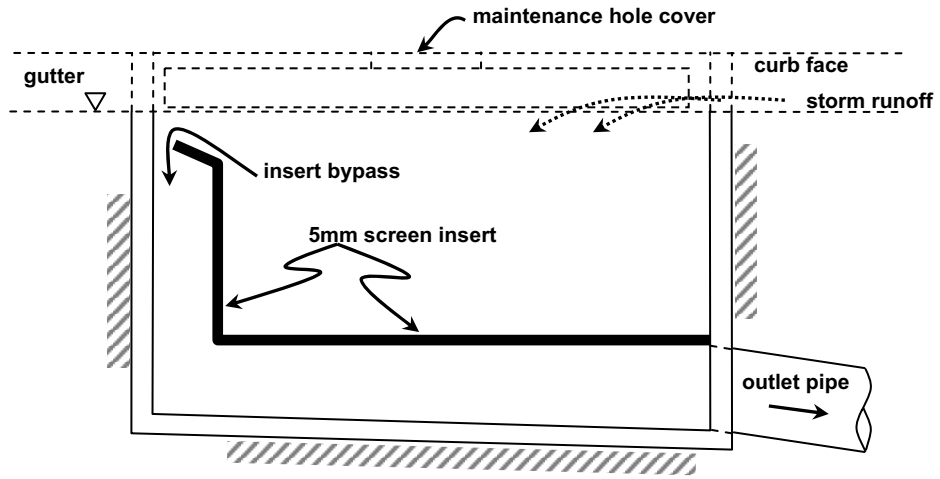

**Figure 1. Evolution of catch basin inserts in the City of Los Angeles**

As can be seen, the City has examined three distinct configurations of inserts. The hanging basket type insert was examined in pilot installations with discouraging results. The demise of the basket insert is its limited capacity for trash capture and the associated tedious maintenance requirements. The City did not proceed with extensive installations of this insert but opted to proceed with that of the horizontal and vertical insert that are described below. The approach described herein will apply to both the horizontal and vertical inserts.

The horizontal insert (See Figure 2) was considered because it addressed the City's concern for increasing trash capture and improving maintenance. The inserts are manufactured from hot dipped galvanized steel or 316-stainless steel sheets with 5 millimeter (0.197 inch) diameter circular openings. Inserts installed in curb opening catch basins encompass the entire width and approximately 85% of the entire length of the basin. An overflow is provided to alleviate hydraulic conditions from major rain events to ensure public safety. Figure 2 depicts typical insert installation in curb opening catch basins. Those installed in grated inlets fit the entire opening. The City has installed several hundred of these inserts in the high trash areas.

The vertical insert is the last in the evolution of inserts that the City is deploying in the high trash areas. The inserts are manufactured from 304-stainless steel, gauge 14, screen sheets with 5 millimeter (0.197 inch) diameter circular openings. These inserts only have a vertical component and are installed just outside the outlet pipe of the catch basin. See Figure 3 for typical insert installation. The insert extends vertically to approximately 2-inches to 3-inches below the bottom lip of the curb opening. This insert has an overflow to alleviate hydraulic conditions from major rain events to ensure public safety. The absence of a horizontal screen allows for increase trash capture volume and lessens the frequency of inserts' maintenance. The City has installed several thousands of these inserts in the high trash areas.



Profile

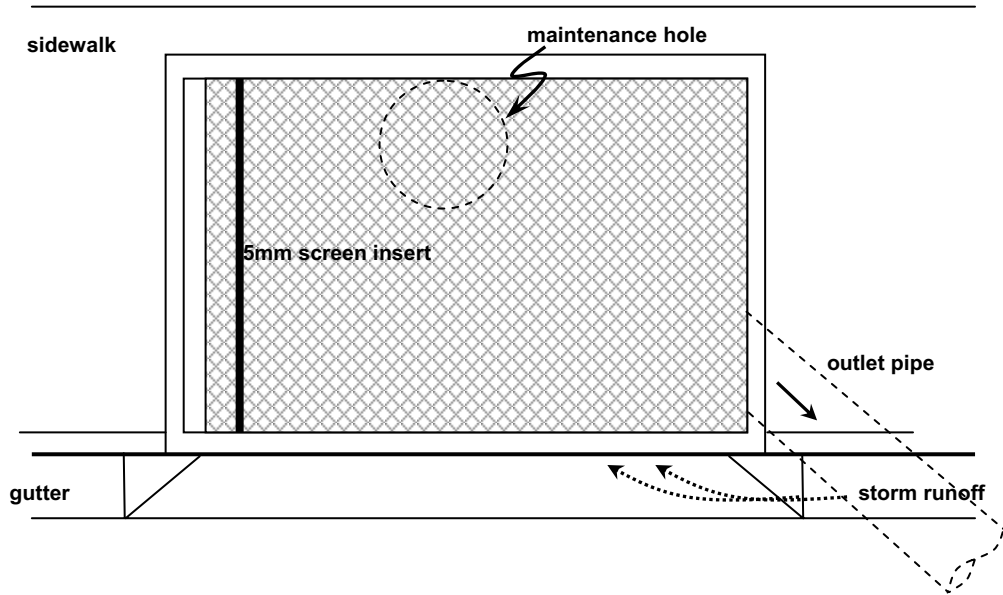

Plan

Figure 2. Typical City of Los Angeles horizontal insert installation

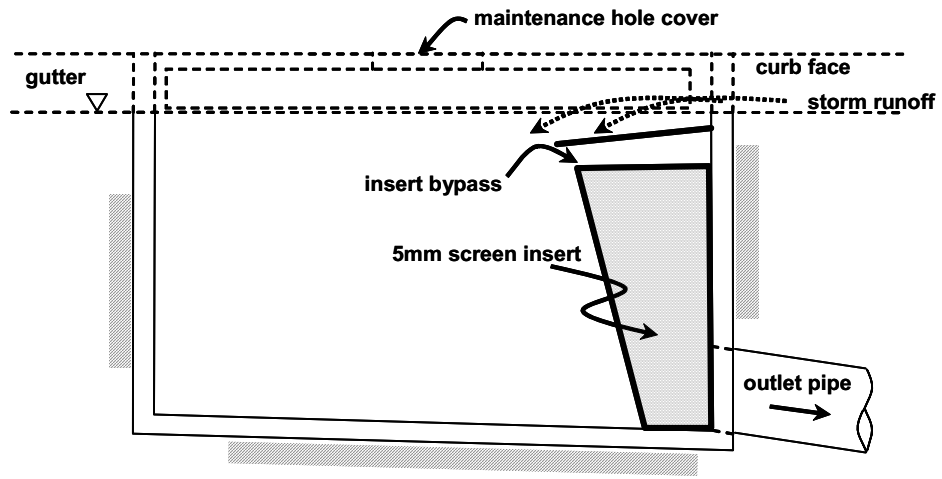

**Profile**

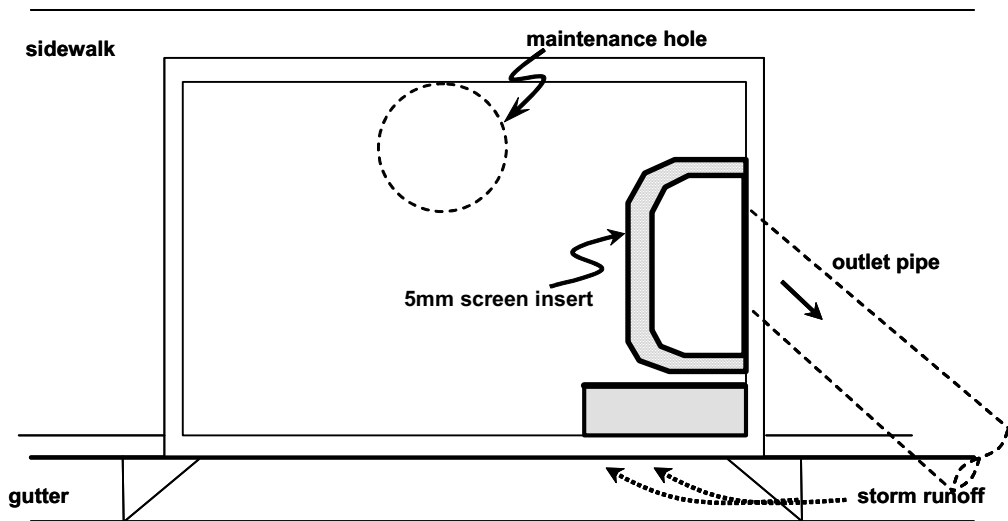

**Plan**

**Figure 3. Typical City of Los Angeles vertical insert installation**

## Method

The following assertions are made:

1. Catch basins in the City of Los Angeles have been designed to intercept runoff from a ten-year storm. (Source: City of Los Angeles, Bureau of Engineering, Storm Drain Design Manual, Part G, Section G222, June 1969).
2. Catch basin outlet pipes have been designed to be a minimum of 18 inches. (Source: City of Los Angeles, Bureau of Engineering, Storm Drain Design Manual, Part G, Section G353, June 1969).

The following steps are taken to determine if the inserts with 5 millimeter are full capture devices, i.e., will treat flows from a 1-year, 1-hour storm.

1. Determine the gross area of the CB insert installed within the catch basin, both horizontal and vertical sections.
2. Determine the percentage (%) open area of the CB insert. Percentage was provided by the manufacturer.
3. Determine the net area of the CB insert. This is done by multiplying the gross area by the percentage of the open area.
4. Determine an effective pipe diameter based on the net area of the CB insert. This is done by using the area of a circle equation and solving for the diameter.
5. Interpretation of effective pipe diameter:
  - a. Greater than 18 inches would indicate that the CB insert can treat more flow than existing CB outlet pipe, thus it will pass flow from a ten-year storm.
  - b. Less than 18 inches would indicate the CB insert is unable to pass more flow than existing CB outlet pipe, thus it will not pass flow from a ten-year storm.
    - i. Proceed in calculating the 1-year, 1-hour storm flow for the CB of concern using the Rational Method and using the rain intensity as determined by the County of Los Angeles intensity isohyetal map for Los Angeles County.
    - ii. Determine an effective pipe diameter that would transport the 1-year, 1-hour flow determined above.
    - iii. Compare effective pipe diameter with actual outlet diameter. If actual outlet diameter is smaller than effective pipe diameter, insert is a full capture device.

## Example – Horizontal Insert

The example below is presented to illustrate the sequence of the method proposed.

Problem: Determine if the **horizontal** insert acts as a full capture device.

Given:

1. CB insert dimensions  
horizontal section is 3.5 feet by 3.6 feet  
vertical section is 1.5 feet by 3.5 feet
2. Tributary area of CB is 120 feet by 150 feet (0.41 acres)
3. Rainfall intensity is 0.52 in/hr
4. Percent open area of insert is equal to fifty percent (50%)
5. Street slope is 0.002 ft/ft

Solution:

1. Determine Gross Area:  
horizontal section =  $3.5\text{ ft} \times 3.67\text{ ft} = 12.85\text{ ft}^2$   
vertical section =  $1.5\text{ ft} \times 3.67\text{ ft} = 5.5\text{ ft}^2$   
Total Gross Area =  $12.85\text{ ft}^2 + 5.5\text{ ft}^2 = 18.35\text{ ft}^2$
2. Percent open area of insert:  
Open area = 50%
3. Determine Net Area of Insert:  
Net Area =  $18.35\text{ ft}^2 \times 50\%$   
Net Area =  $9.18\text{ ft}^2$
4. Determine Effective Pipe Diameter ( $d_{\text{new}}$ ):  
Area of Circle =  $\frac{\pi d^2}{4}$   
$$d_{\text{new}} = \left[ \frac{4 \times \text{area}}{\pi} \right]^{\frac{1}{2}}$$
$$d_{\text{new}} = \left[ \frac{4 \times 9.18\text{ ft}^2}{\pi} \right]^{\frac{1}{2}}$$
$$d_{\text{new}} = 3.42\text{ ft}$$

5. Interpretation of Effective Pipe Diameter:  
The *effective pipe diameter* resulted in 3.42 ft. This diameter is greater than 18 inches, thus CB insert can pass/treat more flow than the existing outlet pipe which is designed for a 10-

year storm, so at this point we can stop and conclude that this insert is a full capture device.

## Example – Vertical Insert

The example below is presented to illustrate the sequence of the method proposed.

Problem: *Determine if the **vertical** insert acts as a full capture device.*

Given:

1. CB insert dimensions  
vertical section is 1.5 feet by 3.5 feet
6. Tributary area of CB is 120 feet by 150 feet (0.41 acres)
7. Rainfall intensity is 0.52 in/hr
8. Percent open area is equal to fifty percent (50%)
9. Street slope equals 0.002 ft/ft

Solution:

1. Determine Gross Area:

$$\text{vertical section} = 1.5 \text{ ft} \times 3.67 \text{ ft} = 5.5 \text{ ft}^2$$

$$\text{Total Gross Area} = 5.5 \text{ ft}^2$$

2. Percent open area of insert:

$$\text{Open area} = 50\%$$

3. Determine Net Area of Insert:

$$\text{Net Area} = 5.5 \text{ ft}^2 \times 50\%$$

$$\text{Net Area} = 2.75 \text{ ft}^2$$

4. Determine Effective Pipe Diameter ( $d_{\text{new}}$ ):

$$\text{Area of Circle} = \frac{\pi d^2}{4}$$

$$d_{\text{new}} = \left[ \frac{4 \times \text{area}}{\pi} \right]^{\frac{1}{2}}$$

$$d_{\text{new}} = \left[ \frac{4 \times 2.75 \text{ ft}^2}{\pi} \right]^{\frac{1}{2}}$$

$$d_{\text{new}} = 1.87 \text{ ft}$$

5. Interpretation of Effective Pipe Diameter:

The *effective pipe diameter* resulted as 1.87 ft. This diameter is greater than 18 inches, thus CB insert can pass more flow than the existing outlet pipe which we assume was designed for a 10-year storm, so at this point we can stop and say that this insert indeed is a full capture device.

## **Discussion**

The above approach provides a method that can be easily applied to the inserts currently being used by the City to demonstrate their use as full capture devices. The initial calculations, allow us to see if placement of the catch basin (CB) insert would hinder the existing conditions of the CB. In the example above, the dimensions given are for a shallow basin found in the City's storm drain system and thus the insert installed would have the smallest opened surface area that could be expected. One would expect the open area of the inserts to increase for larger CBs with longer curb openings (varying from 7 ft to 48 ft long) and depth varying from 4 ft to 12 ft. The example illustrates that even inserts with minimal opened surface area that could be expected in shallow CBs are adequate to handle the 10-year flow that the CB is designed to intercept, but as well can easily accommodate the 1-year, 1-hour rain intensity.